

SANYO

Digital Video Recorder

DSR-3506P

Manual for Remote Operation
by Network Connection

DSR-3506

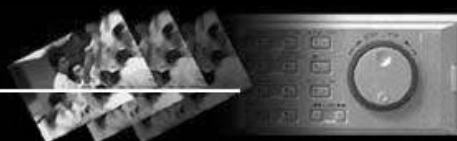

CONTENTS

NETWORK CONTROL

1 NETWORK CONTROL FUNCTION	2	Controlling from a PC	5
Operations possible with PC control	2	Controlling from the unit	7
Network settings	2	Messages displayed when connected	7
2 PREPARING FOR NETWORK CONTROL ...	5	3 OPERATION PANEL FUNCTIONS	
		AND RESTRICTIONS.....	8

NETWORK SETTINGS

1 SETTINGS	9	7. PROGRAM REC SET	16
Making menu selection	9	8. TIMER SET	17
Menu structure	10	9. ALARM REC MODE SET	18
2 MENU-SPECIFIC SETTINGS	11	10. DISPLAY SET	20
1. CLOCK SET	11	11. BUZZER SET	21
2. SUMMER TIME SET/EXT. CLOCK SET ..	11	12. HDD SET	22
3. HOLIDAY SET	12	13. NETWORK SET	22
4. RECORDING AREA SET	13	14. RS-485 SET	23
5. RECORDING CONDITIONS SET	14	15. MASK SET	24
6. NORMAL REC MODE SET	15	16. POWER FAILURE/USED TIME	24
		17. INITIALIZED RECORD	24

NETWORK OPERATION

1 RECORDING IMAGES	25	3 SEARCH MODE	33
Normal recording	25	Basic operation	33
Timer recording	25	Search menu	33
Alarm recording	25	4 OPERATIONS IN SEARCH MODES	34
Pre-alarm recording	25	1. ALARM SEARCH	34
Screen display items	26	2. ALARM THUMBNAIL SEARCH	34
2 WATCHING IMAGES	28	3. TIME/DATE SEARCH	35
Watching live images during playback	28	4. ARCHIVE AREA SEARCH	35
Playing back recorded images	28	5. MOTION DETECTION SEARCH	36
Specifying the number of screens to display ...	29	5 SAVING RECORDED IMAGES	37
Performing operations in play mode	29	Copying to the archive area	37
Adjusting the image and audio	30	Downloading to a PC	38
Screen display items	31	* Image viewer screen	39
Settings for downloading live images to a PC	31		

DVR VIEWER

1 DVR VIEWER	40
Operating environment	40
Installing the DVR Viewer	40
Opening and closing DVR Viewer	41
Menu structure	41
Opening files	42
Viewing images	43
Printing images	45

Copyright

This manual and software are copyrighted by Sanyo Electric Co., Ltd.
Microsoft, Windows, and Window NT are registered trademarks of Microsoft Corporation. Internet Explorer is a registered trademark of Microsoft Corporation.
Other company names and product names mentioned in this manual are trademarks or registered trademarks of their respective holders.

PC control (i.e., remote control) will be possible when this unit is connected to a network.

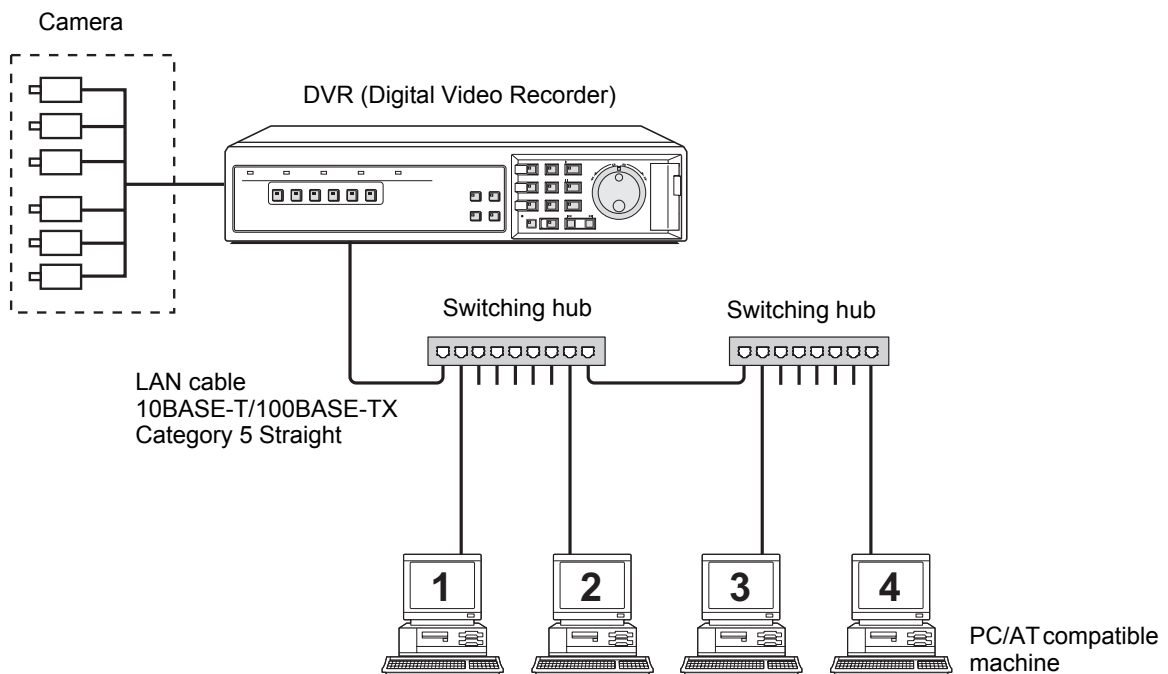

Operations possible with PC control

- Menu settings, recording, playback, and other similar operations will be possible from the PC screen.
- Up to a maximum of four PCs can be simultaneously connected to a single DVR (Digital Video Recorder). (Example)
 - Users with user level ID1: 3 PCs
 - Users with user level ID2 or ID3: 1 PC
- Control of the DVR can be freely switched from the unit itself to the PC and vice versa. Note that operation of the unit will not be affected by simply connecting a cable.
- In order to provide security for computer control, three types of password are set in accordance with the different user levels, and this ensures that three different levels of restrictions can be introduced for operations. (→P. 23)

Network settings

- When this unit is being used while connected to a network, network settings must be made on the unit itself. See INSTRUCTION MANUAL "Network settings" for more details.
- TCP/IP settings must be made on the connected PCs and in accordance with the operating system (OS) being used on each.

! CAUTION

- When a pre-existing network is being used, a check must be carried out by that network's administrator to confirm that IP addresses do not coincide with other IP addresses already in use.

Saving and playing back sound

- The dedicated application DVR Viewer (Ver. 1.5 or later) must be installed on the system in order to store or playback audio on a networked PC or to playback sound-containing video that has been stored on a PC, CompactFlash card, or the like. Please download this software from our homepage (see below).

Sanyo website URL:
<http://www.sanyosecurity.com>

Installing DVR Viewer

(1) Double-click the DVR Viewer's "Setup.exe" icon in order to launch the installer.

After several moments, the "InstallShield Wizard" window will be displayed and installation will start.

When installation has ended, the "Maintenance Complete" window will be displayed.

(2) Click [Finish].

This completes the DVR Viewer installation procedure.

Setting Internet Options

After installing DVR Viewer, use the following procedure to make Internet security settings.

1 Select "Internet Options..." from the Internet Explorer "Tools" menu.

The "Internet Options" window is displayed.

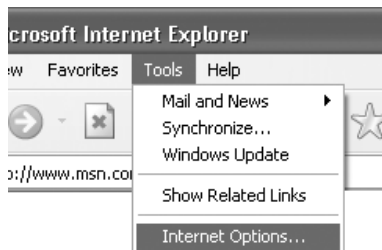

2 Click the "Security" tab.

The "Security" screen is displayed.



3 Click "Custom Level...".

The "Security Settings" screen is displayed.



Confirm that "Run ActiveX controls and plug-ins" is set to "Enable".

If this is not the case, click "Enable" for "Run ActiveX controls and plug-ins", and then make the following settings.

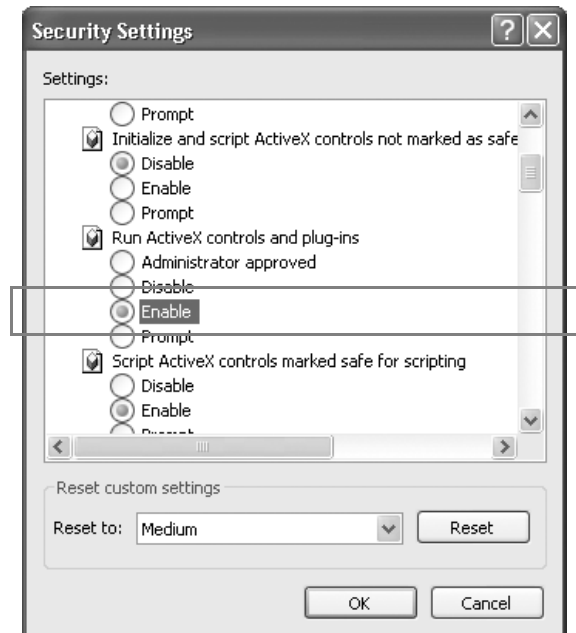

This completes the Internet security setting procedure.

Minimum system requirements

Computer: PC/AT compatible machine
 Operating system: Windows 98/98SE/Me/NT4.0/2000/XP
 Browser: Internet Explorer Ver. 5.0 or later
 Video: 65,000 colors, resolution 800 x 600 dpi or higher

Recommended specifications

CPU: Pentium® III (500 MHz) or better
 RAM: 256 MB minimum
 OS: Windows 2000, XP, or later

Audio playback requirements

DirectX or compatible sound card
 Speaker

For Windows XP

The following example applies to Windows XP.

Transmission control protocol/Internet protocol (TCP/IP) is the standard protocol used for Internet and Intranet. If this unit is to be used when connected to a network, specify a TCP/IP to suit each operating system for the computer that is used for the settings.

1 Click the [Network and Internet Connections] icon in the [Control Panel].

The [Network and Internet Connections] window is displayed.

2 Click [Network Connections].

The [Network Connections] window is displayed, and the settings for the LAN card (Ethernet adapter) being used will appear in the [LAN or High-Speed Internet] column.

3 Right-click on the LAN card (Ethernet adapter) being used, and then select [Properties] from the pop-up menu.

The [General] tab window in the [Local Area Connection Properties] window is displayed.

4 Check that [Internet Protocol (TCP/IP)] is selected in the list of components used by the Ethernet board that appears in the [This connection uses the following items:] box.

If [Internet Protocol (TCP/IP)] is not selected, select it.

5 Click [Properties].

The [General] tab window in the [Internet Protocol (TCP/IP) Properties] window is displayed.

6 Select [Use the following IP address:] and then type in the IP address and the subnet mask.

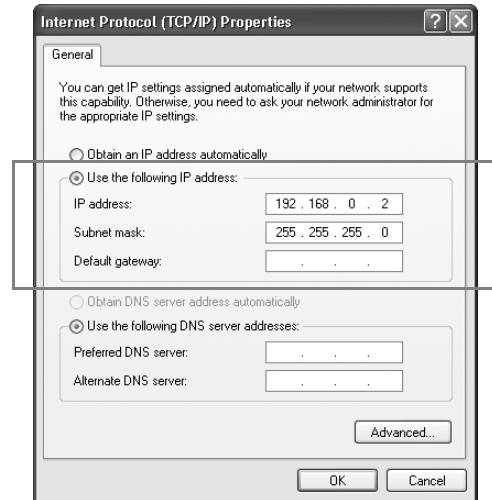

7 Check the settings, and then click [OK].

The display will return to the [Local Area Connection Properties] window.

8 Click [OK].

This completes the TCP/IP settings.

! CAUTION

- Ask the network administrator for details on IP address, subnet mask, default gateway, and DNS settings.

Controlling from a PC

1 Launch the PC's web browser.

Internet Explorer versions 5.0 and later are supported. In terms of OS, Windows 98, 98SE, Me, NT4.0, 2000, and XP are supported.

! CAUTION

- If the Java Script run-time error message is displayed while Internet Explorer is being used, modify that application's settings as follows:
 - (1) Select menus in the sequence [Tools] → [Internet Options] → [Advanced].
 - (2) Uncheck "Display a notification about every script error" from the "Advanced" screen, and check "Disable script debugging".

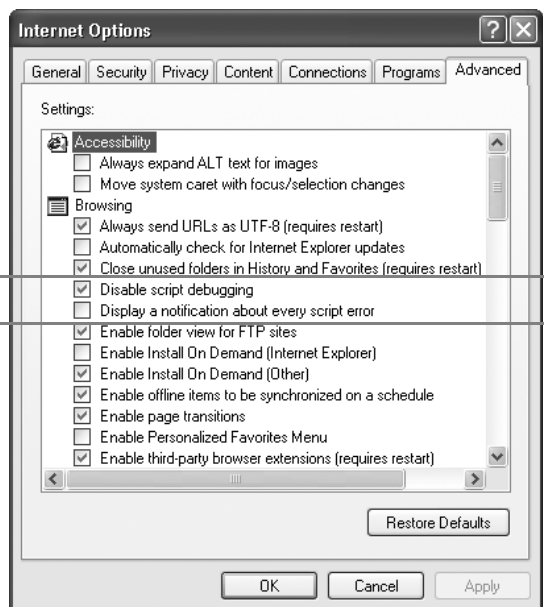

2 Enter the URL.

Enter the unit's URL in the browser's address bar and then press [Enter]. (Note that the URL should contain the IP address specified using the unit's network settings.) To start, enter "http://192.168.0.1/" as the default setting.

! CAUTION

- If a value other than "80" is set as the default port value, enter a colon (:) and then the port number after the IP address. For example, if the port number was set as "81", you should enter http://192.168.0.1:81/
- If no web browser is installed on the PC, Internet Explorer must be installed before proceeding.

3 Enter a password (for verification purposes).

Enter a [User name] and a verification-use [Password] on the [Connect to 192.168.0.1] screen, and then click [OK]. If you entered an incorrect password, the password entry screen will appear once again and you will be prompted to re-input the password.



- Passwords should be setup in advance for the hardware environment's different user levels. At the time of purchase, the password settings (i.e., user name and password) will be as described on P. 23.
- If you save the [User name] and [Password] that have been entered, verification will be carried out automatically on subsequent occasions, and they will not need to be entered again. Note, however, that it may not be possible to save a password other than that used for the default connection.
- Up to four PCs can be connected simultaneously to a single DVR. Note, however, that users with user level ID2 or ID3 are restricted to use of one PC.

! CAUTION

- When four PCs are connected and access is made from a different PC using the highest user level, the most-recent user of a lower level to have accessed the unit will be automatically disconnected and priority will be given to the upper-level user. An error message will appear on the disconnected user's PC. (→P. 7)
- When [Cancel] is clicked after repeated input of an incorrect password, the authentication error message will be displayed.
- Even if computer control is being carried out, clicking a button for which you do not have authorization will result in the password input screen being displayed to verify allocation of the required user level.
- In the case of certain PC performance levels and specifications, a portion of the video may not be displayed. If this is the case, go to [Tools]→[Internet Options] → [Temporary Internet Files] → [Settings] in Internet Explorer, and then reduce "Amount of disk space to use".

4 Entering the operation screen

- (1) The following screen will be displayed when password verification has been completed successfully.



- (2) Select the language and click [OK]. The operation screen will be displayed and computer control will now be possible.

! CAUTION

- Connection will not be possible when a menu screen is being displayed on the DVR unit or when playback-related operations are being carried out. In such a case, cancel the menu screen selection or stop the playback operation before attempting to remake connection.
- Connection may not be possible via a proxy server. In such a case, cancel the proxy settings.

Controlling from the unit

Whenever the  button on the PC's operation screen is clicked, access will be cancelled and control rights will switch back to the unit.

NOTE

- To forcibly cancel PC access from the unit, press and hold the [EXIT] button for at least 2 seconds.
- Access from the PC will not be permitted for a period of 10 seconds after access has been canceled.
- The access connection will also be cancelled whenever communication with the PC is not possible for a period of about 1 minute or more, and control rights will switch back to the unit in such a case.
- If the browser is closed without clicking the  button, approximately one minute is required before reconnection is possible.

Messages displayed when connected

Messages related to the switching of control or the network connection condition may be displayed on-screen at any time.

Display on the unit

1 When control rights are switched to the PC

"NETWORK CONTROL" appears on the monitor.

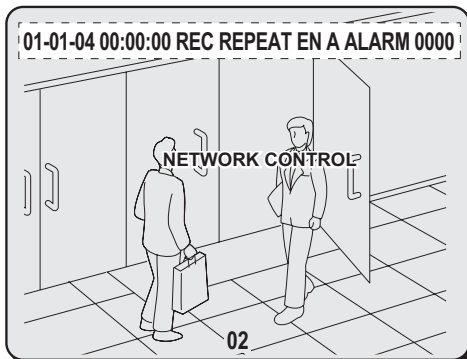

NOTE

- The "NETWORK CONTROL" message is not displayed when "NETWORK STATUS" has been set to "OFF" using the unit's menu. (Regardless of network operations, the unit will continue to display images.)

2 When control rights are switched to the unit

Whenever the  button on the PC's operation screen is clicked, access will be cancelled and control rights will switch back to the unit. In addition, the "NETWORK CONTROL" message from the unit's on-screen display will be changed to "DISCONNECTED".

- Once the message has changed to "DISCONNECTED", it can be cleared by pressing any of the unit's buttons.

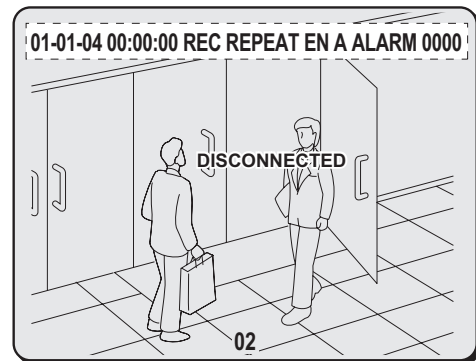

3 Forced disconnection from the unit

To forcibly cancel access by a PC, press and hold the unit's [EXIT] button for at least 2 seconds. When access is forcibly cancelled in this way, the "NETWORK CONTROL" message will be replaced with "DISCONNECTED".

- Access from the PC will not be permitted for a period of 10 seconds after access has been canceled.

Display on the PC

1 When disconnected from the network

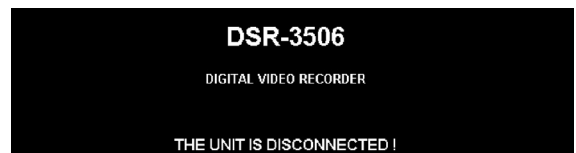

2 When access cannot be made to a connected DVR



3 When accessing a DVR that is already connected to another 4 PCs



Operation panel

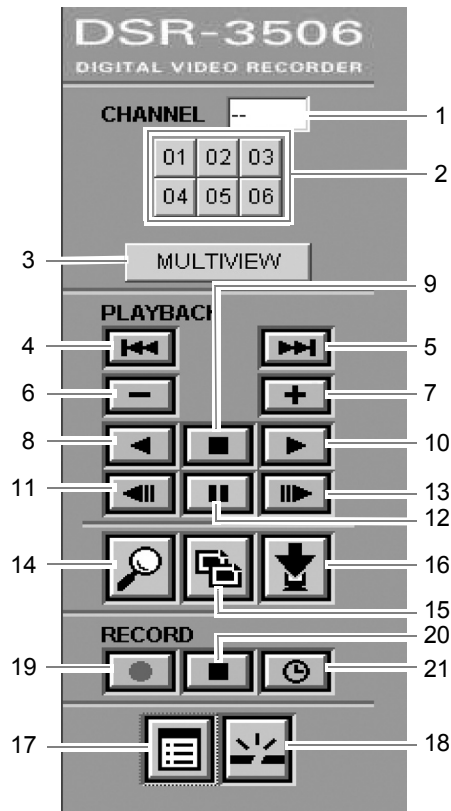

Channel and screen selection buttons

1. Channel number

Displays the channel number selected using "2. Channel selection" below.

2. Channel selection (ID1/2/3)

Used to select a camera channel when displaying video on a single screen.

3. [MULTI VIEW] (ID1/2/3)

Used to display video in six split screens.

Playback buttons

4. Previous event (ID2/3)

This button starts playback from the previous alarm event.

5. Next event (ID2/3)

This button starts playback from the next alarm event.

6. Speed down (ID2/3)

This button reduces the playback speed by one setting.

7. Speed up (ID2/3)

This button increases the playback speed by one setting.

8. Reverse playback (ID2/3)

This button starts playback of recorded images in the reverse direction.

9. Playback stop (ID2/3)

This button stops playback and calls up the live display.

10. Playback (ID2/3)

This button starts playback of recorded images.

11. Previous image (ID2/3)

This button moves a still image back by one frame.

12. Still (ID2/3)

This button pauses the image during playback.

13. Next image (ID2/3)

This button moves a still image forward by one frame.

Setting buttons

14. Search (ID2/3)

This button calls up the search screen (i.e., the setting screen).

15. Copy (ID2/3)

This button calls up the copy screen (i.e., the setting screen).

16. Download (ID2/3)

This button calls up the download screen (i.e., the setting screen).

17. Menu setting (ID3)

This button calls up the menu screen (i.e., the setting screen).

18. Disconnect (ID1/2/3)

This button disconnects the PC from the network and switches control rights to the unit.

Recording buttons

19. Record (ID3)

This button starts normal recording.

20. Record stop (ID3)

This button stops normal recording.

21. Timer (ID3)

This button activates timer standby mode when clicked while recording is stopped. If clicked in Timer Standby mode, it deactivates this mode.

* Entries in parentheses refer to user level restrictions for the specific button. (→P. 23)

Before using the unit, settings should be made for recording conditions, installation environment, and other similar factors. The corresponding menu items are displayed in a two-level structure comprising main menus and sub-menus.

For more details regarding setting methods, see "2. MENU-SPECIFIC SETTINGS" (→P. 11).

Making menu selection

1 Click the button on the operation panel.

The MAIN MENU screen is displayed.

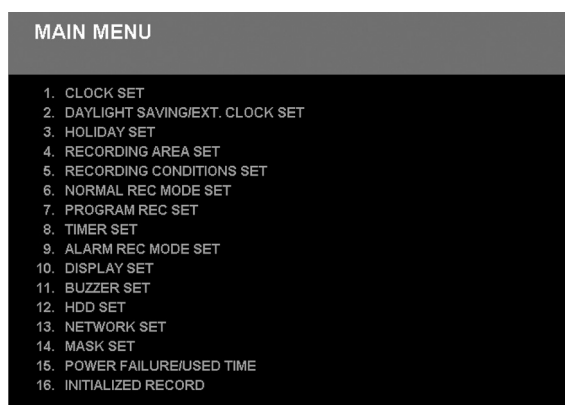

2 On the MAIN MENU screen, select and click the menu to be used.



The corresponding sub-menu screen appears.

3 Make the required settings.

4 When settings have been completed, click the (Playback stop) button on the operation panel.

The normal screen (monitoring image) is displayed.

NOTE

- Menu screens will not be displayed during playback. In such a case, stop playback, return to live mode, and then click the  button.
- You must be connected with user level ID3 to modify settings.
- It will not be possible to modify settings when the unit is recording.
- To move from one sub-menu to another, click the  button to return first of all to the MAIN MENU.

Menu structure

	Main menu	Sub menu	Reference page
Recording conditions	1. CLOCK SET	● CLOCK SET	11
	2. SUMMER TIME SET/ EXT. CLOCK SET	● SUMMER TIME SET ● EXT. CLOCK SET	11
	3. HOLIDAY SET	● HOLIDAY SET	12
	4. RECORDING AREA SET	● TOTAL CAPACITY ● Area-specific capacity ● AREA FULL RESET	13
	5. RECORDING CONDITIONS SET	● NORMAL RECORDING AREA OVERWRITE ● ALARM RECORDING AREA OVERWRITE ● REMAINING DISK WARNING ● AUTO DELETE	14
	6. NORMAL REC MODE SET	● PICTURE QUALITY ● AUDIO RECORDING ● REC RATE ● PROGRAM GROUP	15
	7. PROGRAM REC SET	● PROGRAM REC SET	16
	8. TIMER SET	● TIMER SET	17
	9. ALARM REC MODE SET	● ALARM RECORDING ● PICTURE QUALITY ● AUDIO RECORDING ● ALARM INTERLEAVE (REC RATE, DURATION) ● PRE-ALARM RECORDING (REC RATE, DURATION) ● ALARM TRIGGER	18
Installation environment	10. DISPLAY SET	● DATE ● TIME ● QUALITY ● AUDIO ● ALARM COUNT ● ALARM TYPE ● TITLE	20
	11. BUZZER SET	● ALARM ● DISK FULL ● DISK ERROR ● LOCK WARNING ● KEY IN ● NON REC	21
	12. HDD SET	● Hard disk capacity ● MIRRORING ● PLAYBACK DRIVE	22
	13. NETWORK SET	● IP ADDRESS ● SUBNET MASK ● GATEWAY ● PORT ● PASSWORD SETTING ● NETWORK SPEED	22
	14. RS-485 SET	● DATA SPEED ● STATUS INFO ● ALARM INFO ● ADDRESS	23
	15. MASK SET	● MASK (MAIN, MON.2, NETWORK) ● TIME PERIOD ● Channel	24
	16. POWER FAILURE/ USED TIME	● POWER FAILURE ● USED TIME ● FIRMWARE	24
	17. INITIALIZED RECORD	● DATE ● TIME ● AREA	24

* indicates the display of information only.

NOTE

- Pull-down menus



When a pull-down menu is clicked, the list of available selections will be displayed. Select the required value.

1. CLOCK SET

Set the unit's time and date as described below. Be sure that the date and time are set correctly at this time.

- 1 Select the “Day/Month/Year/Hour/Minutes” field from the pull-down menu on the screen.

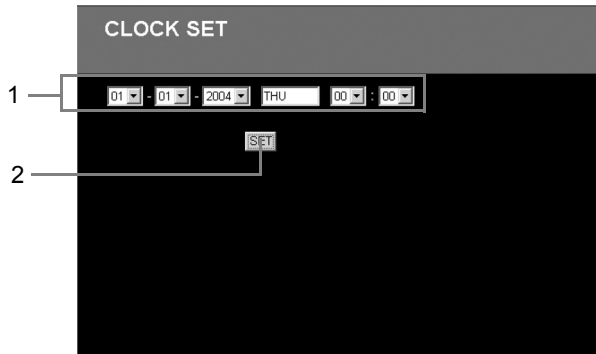

The day of the week will be set automatically based on the date.



- 2 Click [SET].

The current time is set.

! CAUTION

- Recording mode may not be activated if a time has not been set. In such a case, the following warning will be displayed when you click the  button or the  button.
“PLEASE SET THE CLOCK”

2. SUMMER TIME SET/EXT. CLOCK SET

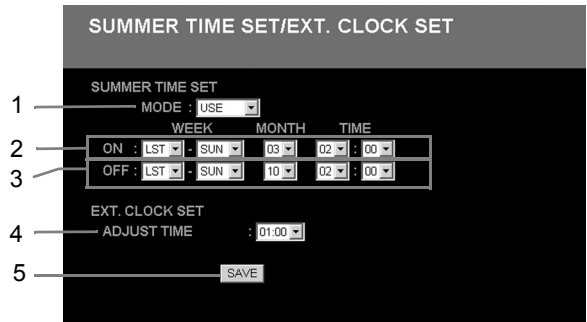

SUMMER TIME SET setting

- 1 Change the setting for summer time from the pull-down menu on the screen.

[Settings] (◆ indicates default setting.)

Setting	Description
◆USE	Time is automatically adjusted to summer time.
NO USE	Time is not automatically adjusted to summer time.

- 2 Set the date/time at which to switch from standard time to summer time from the pull-down menu on the screen.
- 3 Set the date/time at which to switch from summer time to standard time from the pull-down menu on the screen.

EXT. CLOCK SET setting

Synchronized operation will not be possible when time differences exist between the unit and the connected peripheral devices. By setting the external time as described here, all devices connected to the clock adjust terminal can be set to the same time.

- 4 Select “ADJUST TIME” from the pull-down menu on the screen.

Each day at the specified time, a signal will be output to adjust the time of connected devices.

(Default setting: 01:00)

- 5 Click [SAVE].

The summer time or adjustment time is set.

3. HOLIDAY SET

Set specific days as holidays using the procedure described below.

When a day is specified as a holiday, timer recording for that day will be carried out as if it were a Sunday.

Dates such as national holidays and company off days should be set as holidays when you want those dates to have the same security as Sundays.

The screenshot shows a screen titled "HOLIDAY SET" with a grid of 20 rows and 2 columns of pull-down menus. Each row is numbered 1 through 20. The left column contains pull-down menus for selecting the day of the month, and the right column contains pull-down menus for selecting the month. A "SAVE" button is located at the bottom right of the screen. A line labeled "1" points to the first row's pull-down menus, and a line labeled "2" points to the "SAVE" button.

- 1 Specify the day to be treated as a holiday from the pull-down menu on the screen.**

Left side: Day Right side: Month

A maximum of 20 different days can be specified as holidays.



- 2 Click [SAVE].**

The saved or modified settings are stored.

4. RECORDING AREA SET

The unit's hard disk is separated into three independent recording areas. Furthermore, five different recording modes can be used for these three areas.

The memory capacity for each area is allocated as a percentage. (Setting units: 1%)

Recording area	Recording mode		Recording method
Normal recording area	Normal recording	Manual	Recording is performed in response to manual operation of the operation panel's  button.
	Timer recording	Automatic	Recording is performed automatically over the time range set using "8. TIMER SET" from the MAIN MENU.
Alarm recording area	Alarm recording	Automatic	Recording is performed automatically upon occurrence of an alarm set using "9. ALARM REC MODE SET" from the MAIN MENU.
	Pre-alarm recording	Automatic	Automatic recording of images before an alarm is performed automatically in accordance with "PRE-ALARM RECORDING" from the MAIN MENU's "9. ALARM REC MODE SET". This is used as a complementary function for alarm recording.
Archive area	Copy	Manual	The required images are copied from another recording area and stored in response to manual operation of the operation panel's  button.

1 Total capacity display

This section displays the total capacity of the hard disk.

NOTE

- If two hard disks are installed and mirroring is set to "ON" using the digital video recorder's hard disk settings, the smaller disk capacity will be shown.

2 Area-specific capacity display

This section displays the capacity set by the unit for each recording area as a percentage of the total capacity.

NOTE

- Setting and modification of recording area capacities cannot be carried out from a PC.

3 Recording area reset

When the overwrite setting is "OFF", recording will be automatically stopped when the corresponding recording area has been filled with image data. In such a case, [AREA FULL RESET] can be clicked to overwrite from the beginning of each area.

NOTE

The ability to perform a reset will not be required in the following cases, and for this reason, [AREA FULL RESET] is not displayed.

- When the capacity setting for both the normal recording area and the alarm recording area is 0%.
- When the overwrite setting is "ON".

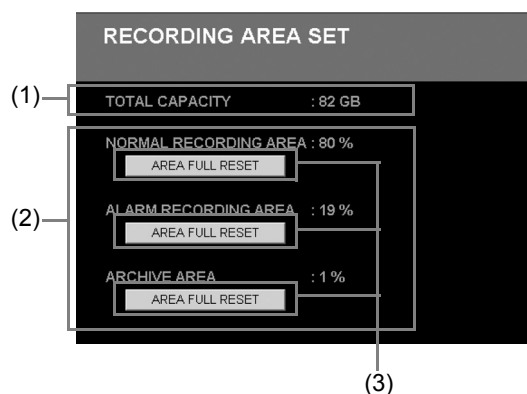

5. RECORDING CONDITIONS SET

Set the permission for overwriting to recording areas or the remaining-space warning level as described below.



Setting overwriting permission for the normal recording area

When the normal recording area has been filled with data, this setting dictates whether recording will be stopped or continued by overwriting the recorded images currently stored on the hard disk.

1 Select “OVERWRITE” for normal recording area from the pull-down menu on the screen.

[Settings] (◆ indicates default setting.)

Setting	Description
◆ ON	When the normal recording area has been filled with data, overwriting from the beginning of this area will start automatically.
OFF	Recording is stopped when the normal recording area has been filled with data.

Setting overwriting permission for the alarm recording area

When the alarm recording area has been filled with data, this setting dictates whether recording will be stopped or continued by overwriting the recorded images currently stored on the hard disk.

2 Select “OVERWRITE” for alarm recording area from the pull-down menu on the screen.

[Settings] (◆ indicates default setting.)

Setting	Description
◆ ON	When the alarm recording area has been filled with data, overwriting from the beginning of this area will start automatically.
OFF	Recording is stopped when the alarm recording area has been filled with data.

Setting the remaining-space warning level

In situations where the overwrite setting for the normal recording area and the alarm recording area is “OFF”, you can have the unit issue a warning as soon as the remaining space in either of these areas reaches a specific level. (→P. 21)

The following section describes how to set the level at which the warning will be issued.

(This level is common for the normal recording area and the alarm recording area.)

3 Set the remaining-space warning level from the pull-down menu on the screen.

Setting range: 1% to 10% (in units of 1%)

Setting the auto delete

You can set the storage period for images. When the set period has expired, the corresponding data will be automatically deleted.

4 Set “AUTO DELETE” from the pull-down menu on the screen.

[Settings] (◆ indicates default setting.)

Setting	Description
◆ OFF	Auto delete is not to be set
1 -99 DAYS	You can set the storage period for recorded data within a range of “1 DAY” - “99 DAYS” (full days).

! CAUTION

- If the overwrite setting for the normal recording area and the alarm recording area is “ON”, the remaining-space warning level will be displayed as “***” and setting will not be possible.

5 Click [SAVE].

The new setting is saved.

6. NORMAL REC MODE SET

Set conditions for normal recording and timer recording as described below.

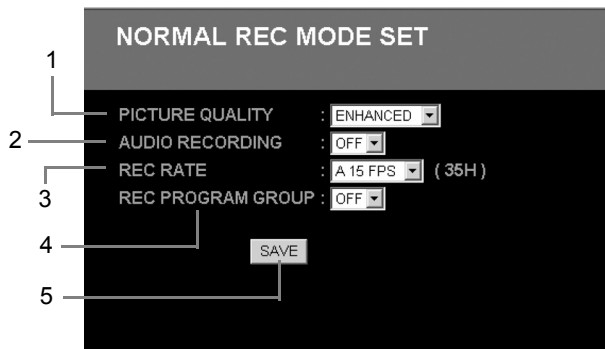

Setting the picture quality for recording

Set the picture quality for recording to the normal recording area as follows.

1 Select “PICTURE QUALITY” from the pull-down menu on the screen.

[Settings] (◆ indicates default setting.)

Setting	Description
SUPER FINE	Super Fine
FINE	Fine
◆ENHANCED	Enhanced
NORMAL	Normal
BASIC	Basic

Setting audio recording

Audio can be recorded together with images when performing normal recording.

Note, however, that since this audio data will also be stored in the normal recording area, the recording time for this area will be reduced.

2 Select “AUDIO RECORDING” from the pull-down menu on the screen.

[Settings] (◆ indicates default setting.)

Setting	Description
ON	Audio will be recorded.
◆OFF	Audio will not be recorded.

NOTE

- Audio recording can only be specified when the recording rate is A60 to A1 FPS.

Setting the recording rate

Set the recording rate for normal recording as follows. (Default setting: A15 FPS)

3 Select “REC RATE” for normal recording from the pull-down menu on the screen.

Audio recording is carried out	A60, A30, A20, A15, A10, A7.5, A6, A5, A4.286, A3.75, A3.333, A3, A2.727, A2.308, A2, A1.667, A1.429, A1.25, A1.111, A1
Audio recording is not carried out	0.5, 0.333, 0.25, 0.2, 0.1, 0.05, 0.033

The letter “A” will be displayed in front of recording rates that can be set for audio recording.

Selecting setting values

Image resolution is determined by the product of picture quality and recording rate. The higher the picture quality and the faster the recording rate, the better the image resolution; however, as higher resolution requires more storage capacity, the recording time will be reduced accordingly.

NOTE

- The recording rate will be limited between A30 and 0.033 FPS when the setting for pre-alarm recording is “ON”.
- The recording rate for timer recording should be set separately using the TIMER SET menu. (→P. 17)

4 Select “REC PROGRAM GROUP” from the pull-down menu on the screen.

Select OFF, P-1, P-2, P-3, or P-4.

NOTE

- Settings for program groups should be made separately as described in “7. PROGRAM REC SET”. (→P. 16)

5 Click [SAVE].

The new setting is saved.

7. PROGRAM REC SET

When monitoring a number of cameras connected to this digital video recorder, a separate recording rate can be set for each camera. In addition, video recorded from each camera and the corresponding recording rates can be set in programs with up to four patterns, thus facilitating the simple specification of programs for timer-setting and normal recording setting menus.

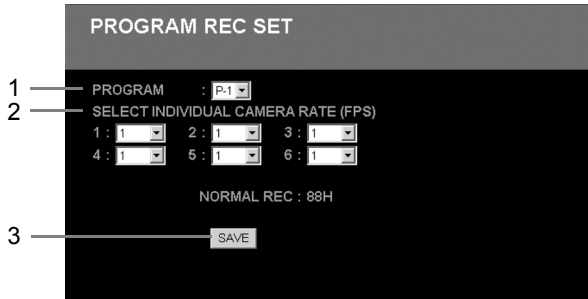

Set the picture quality for recording to the normal recording area as follows.

1 Select “PROGRAM” from the pull-down menu on the screen.

Select from P-1 through P-4.

2 Select “SELECT INDIVIDUAL CAMERA RATE (FPS)” from the pull-down menu on the screen.

Of the displayed cameras, select those from which video is to be recorded, and then set a recording rate for each.

[Settings] (◆ indicates default setting)

Setting	Description
OFF	Video will not be recorded from the selected camera.
◆ REC RATE	Sets the rate for recording.

- Usable recording rates
30, 15, 7.5, 3.75, 1.875, 1, 0.5, 0.33, 0.25, 0.2, 0.1, 0.05, 0.03
(Unit: FPS)

NOTE

- The recording rates listed in pull-down menus vary according to the connected channels.

3 Click [SAVE].

When setting has been completed, the associated normal recording time quantity is displayed for reference purposes.

4 Use the above procedure to set up to four program patterns.

! CAUTION

- Set values are lost if switched to a different window without clicking [SAVE].

8. TIMER SET

Set timer operation duration and timer recording conditions on a day-specific basis as shown below.

	(1) WEEK	(2) START	(3) STOP	(4) PROGRAM	(5) REC RATE	(6) SET
	SUN	-- :--	-- :--	OFF	A 15 FPS	OFF
	MON	-- :--	-- :--	OFF	A 15 FPS	OFF
	TUE	-- :--	-- :--	OFF	A 15 FPS	OFF
	WED	-- :--	-- :--	OFF	A 15 FPS	OFF
	THU	-- :--	-- :--	OFF	A 15 FPS	OFF
	FRI	-- :--	-- :--	OFF	A 15 FPS	OFF
(7)	SAT	-- :--	-- :--	OFF	A 15 FPS	OFF
(8)	DLY	-- :--	-- :--	OFF	A 15 FPS	OVER 24H
2	EXT	** : **	** : **	OFF	A 15 FPS	OFF

For setting timer recording spanning more than 24 hours

1 Setting timer recording conditions for different days of the week.

(1) WEEK

These fields specify the days of the week for timer recording. By using multiple setting rows, it is possible to setup timer recording a number of different times on a single day.

(2) START

These fields are used to enter the time at which to start timer recording.

(3) STOP

These fields are used to enter the time at which to stop timer recording.

(4) PROGRAM

To carry out program recording, select a program (P-1 through P-4). (→P. 16)

(5) REC RATE

These fields set the recording rate. (→P. 15)

To carry out program recording, set to "***".

(6) SET

Set these fields to "ON" to set timer recording.

Set these fields to "OFF" when timer recording is not to be set.

(7) SAT, DLY

When the start and stop times, program, and the recording rate have been entered and "ON" has been selected for "SET", you will be able to carry out timer recording over the same period every day.

(8) EXT

Displays details set by an external timer. (These are not start and end time settings.)

NOTE

- If "DLY" is set for any other day, all rows will adopt this setting.

2 Click [SAVE].

Timer setting (or modification) is completed.

■ Performing timer recording

Click the button on the operation panel. (→P. 8)

■ Overlapping of timer reservation times

- If timer settings overlap, recording is performed in accordance the following priority sequence.
Individual reservations → "DLY" → "EXT"
(High) ← Priority → (Low)
- If a reservation for a particular day overlaps with a daily reservation, priority is given to that with the earliest start time. If both have the same start time, priority is given to that with the highest setting position in the menu.

■ Setting a timer for over 24-hours continuous recording

The bottom two lines of the TIMER SET screen are used to make settings for this type of recording.

- (1) Click [OVER 24H] to switch the setting format.
- (2) Set the day and time for the start of recording in the upper row.
- (3) Set the day, time, program and recording rate for the end of recording in the lower row.
- (4) Select "ON" for "SET" on the bottom row to specify timer recording extending for over 24 hours.

9. ALARM REC MODE SET

Set the recording conditions for alarm recording as follows.

Setting alarm recording

In order to carry out alarm recording, it will be necessary to set operation patterns and recording conditions.

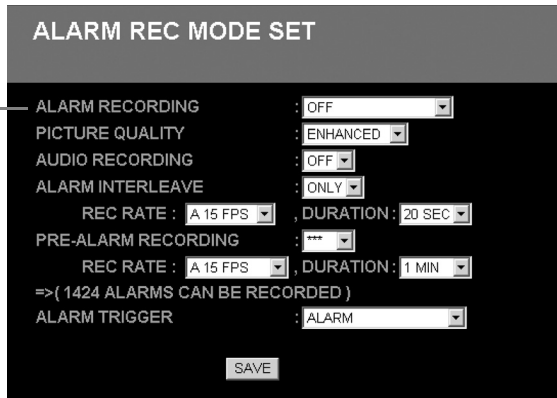

- 1 Select a mode using “ALARM RECORDING” from the pull-down menu on the screen.

[Settings] (◆ indicates default setting.)

Setting	Description
◆ OFF	Does not perform alarm recording.
ENABLED	Alarm recording is always performed, regardless of timer recording or timer settings.
AL-REC ON TIMER	Alarm recording is performed only during timer recording.
AL-REC OFF TIMER	Alarm recording is performed only during recording other than timer recording.
ONLY AL-RC ON TMR	Alarm recording is performed only in the period set for timer recording without timer recording actually being performed.

Setting the alarm interleave

- 4 Select “ALARM INTERLEAVE” from the pull-down menu on the screen.

Setting the picture quality for recording

Set the picture quality for alarm recording as follows.

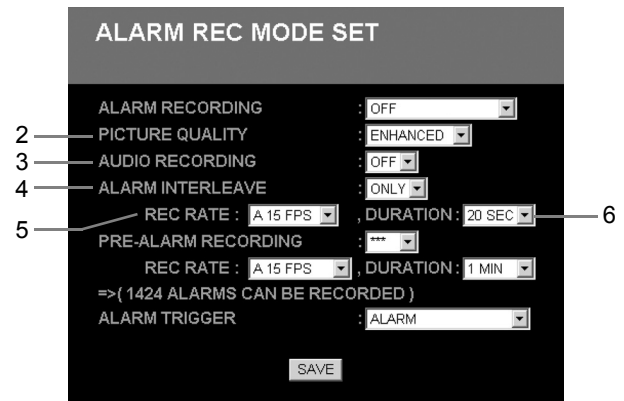

- 2 Select “PICTURE QUALITY” from the pull-down menu on the screen.

[Settings] (◆ indicates default setting.)

Setting	Description
SUPER FINE	Super Fine
FINE	Fine
◆ ENHANCED	Enhanced
NORMAL	Normal
BASIC	Basic

Setting audio recording

Audio can be recorded together with images when performing alarm recording. Note, however, that since this audio data will also be stored in the alarm recording area, the recording time for this area will be reduced.

- 3 Select “AUDIO RECORDING” from the pull-down menu on the screen.

[Settings] (◆ indicates default setting.)

Setting	Description
ON	Audio will be recorded.
◆ OFF	Audio will not be recorded.

NOTE

- Audio recording can only be specified when the recording rate is between A30 and A1 FPS.

[Settings] (◆ indicates default setting.)

Setting	Description
SW	Recording is switched between camera video including an alarm and video from all connected cameras.

◆ ONLY	Video is recorded only from cameras with an alarm occurring.
--------	--

5 Select “REC RATE” from the pull-down menu on the screen.

(Default setting: A15 FPS)

Audio recording is performed	A30, A20, A15, A10, A7.5, A6, A5, A4.286, A3.75, A3.333, A3, A2.727, A2.308, A2, A1.667, A1.429, A1.25, A1.111, A1
Audio recording is not performed	0.5, 0.333, 0.25, 0.2, 0.1, 0.05, 0.033

The letter “A” will be displayed in front of recording rates that can be set for audio recording.

6 Set the duration for alarm recording using “DURATION” from the pull-down menu on the screen.

5 SEC, 10 SEC, 20 SEC, 40 SEC, 1 MIN, 2 MIN, 3 MIN, 4 MIN, 5 MIN, 10 MIN, 15 MIN, CC*¹

(Default setting: 20 SEC)

*¹ Operates while an alarm is being activated.

Setting pre-alarm recording

Set the recording conditions to be used for pre-alarm recording as described below. (→P. 25)

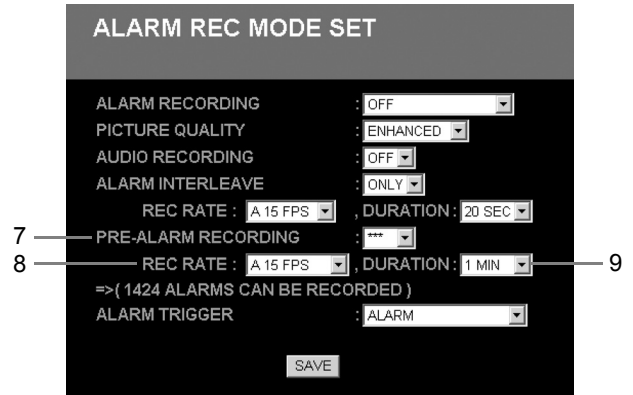

7 Select “ON” or “OFF” using “PRE-ALARM RECORDING” from the pull-down menu on the screen.

[Settings]

Setting	Description
ON	Performs pre-alarm recording.
OFF	Does not perform pre-alarm recording.

NOTE

- When “OFF” has been selected for “ALARM RECORDING”, this item will be displayed as “***” and selection will not be possible.

8 Make a selection for “REC RATE” from the pull-down menu on the screen.

(Default setting: A15 FPS)

Audio recording is performed	A30, A20, A15, A10, A7.5, A6, A5, A4.286, A3.75, A3.333, A3, A2.727, A2.308, A2, A1.667, A1.429, A1.25, A1.111, A1
------------------------------	--

The letter “A” will be displayed in front of recording rates that can be set for audio recording.

9 Set the duration for pre-alarm recording using “DURATION” from the pull-down menu on the screen.

3 SEC, 5 SEC, 10 SEC, 20 SEC, 40 SEC, 1 MIN, 2 MIN, 3 MIN, 4 MIN, 5 MIN, 10 MIN, 15 MIN

(Default setting: 1 MIN)

Setting alarm triggers

Set the alarm triggers (i.e., launch signals) that constitute operation conditions for alarm recording as follows.

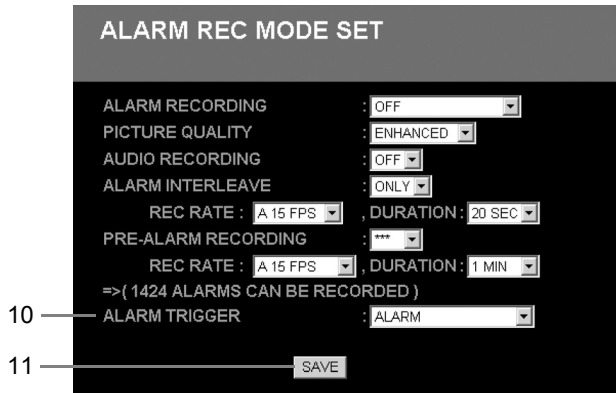

10 Select a launch signal for alarm recording using “ALARM TRIGGER” from the pull-down menu on the screen.

[Settings] (◆ indicates default setting.)

Setting	Description
◆ ALARM	Starts recording when an external alarm is activated.
SENSOR	Starts recording when a motion sensor is activated.
ALARM AND SENSOR	Starts recording when both an external alarm and a motion sensor are activated simultaneously.
ALARM OR SENSOR	Starts recording when an external alarm or a motion sensor is activated independent of the other.

NOTE

- **External alarm detection**
The term “external alarm detection” is used to describe input of an external detection signal from a door switch or the like to the unit’s alarm input terminal.
- **Motion sensor detection**
The term “motion sensor detection” is used to refer to detection of motion on the monitor in accordance with motion sensor settings.
- The setting of motion sensors is carried out using the digital video recorder.

11 Click [SAVE].

The new settings is saved.

10. DISPLAY SET

Set conditions for the display of data on the unit’s monitor by selecting “ON” or “OFF” for each item.

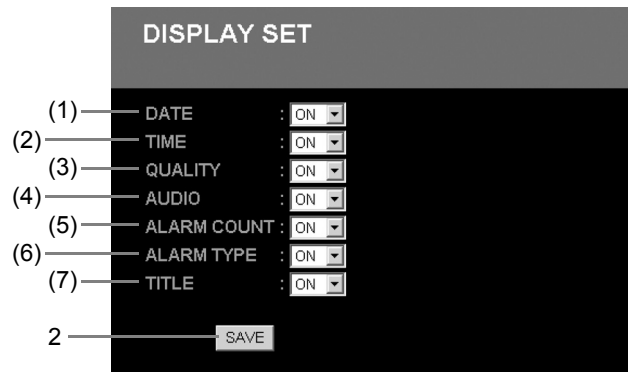

NOTE

- These settings apply to information displayed on the monitor connected to the unit, not to the PC monitor’s display information.

1 Select “ON” or “OFF” for each data display item.

	Item	Default setting	Description
(1)	DATE	ON	Sets whether the current date or recording date will be displayed.
(2)	TIME	ON	Sets whether the current time or recording time will be displayed.
(3)	QUALITY	ON	Sets the picture quality for recording or playback.
(4)	AUDIO	ON	Sets the display condition for audio recording.
(5)	ALARM COUNT	ON	Displays the number of recorded alarms.
(6)	ALARM TYPE	ON	Sets the alarm recording type. <ul style="list-style-type: none"> ● For alarm recording: “ALARM” is displayed ● For pre-alarm recording: “PRE” is displayed
(7)	TITLE	ON	Sets the display condition for camera title.

2 Click [SAVE].

The on-screen data display conditions are set or modified.

11. BUZZER SET

Set a warning buzzer to sound for alarms or when the hard disk space reaches zero as described below.

1 Select "ON" or "OFF" for the alarm buzzer.

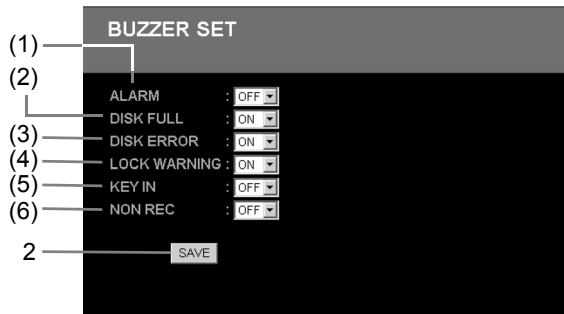

	Item	Default setting	Description
(1)	ALARM	OFF	Sounds a buzzer when an alarm is detected.
(2)	DISK FULL	ON	Sounds a buzzer when the amount of data stored in each of the hard disk's recording areas has reached the remaining-space warning level. (→P. 14)
(3)	DISK ERROR	ON	Sounds a buzzer when a hard-disk error occurs.
(4)	LOCK WARNING	ON	Sounds a buzzer when an operation button not permitted for the current user level is pressed while the security lock is set. Specifically, the buzzer sounds twice with an interval of approximately 0.5 seconds.
(5)	KEY IN	OFF	The buzzer emits a key-operation sound each time a button is pressed.
(6)	NON REC	OFF	Sounds a buzzer when recording is stopped.

2 Click [SAVE].

The new settings are saved.

! CAUTION

- These settings apply to the digital video recorder's buzzer. To sound a buzzer on the PC, refer to NOTE.

NOTE

To sound a buzzer on the PC

- Create a folder named "BUZZER" within the root directory of the PC's C drive.
- Within this folder, save the sound to be used as a buzzer in .wav format and with the name "BUZZER.WAV".

Example: C:\BUZZER\BUZZER.WAV

Once these settings have been made, whenever a key is pressed on the digital video recorder or an error occurs, the PC will provide notification by playing the saved .wav file.

* Only the first second of the saved audio file will be played, and for this reason, it is advisable to choose a file with suitable audio in the first second. Furthermore, the use of large audio files is discouraged.

* The buzzer will only sound in response to alarm input.

To cancel sounding of a buzzer on the PC

- Delete the folder or file created in the above-mentioned process, change the name of the audio file, or move it to a different location on the hard disk.
- Press the  (Playback stop) button to stop the buzzer of PC.

! CAUTION

- Different settings cannot be used for the recorder and the PC.
- When the PC buzzer is sounded, it can be stopped by pressing any button on the digital video recorder.

12. HDD SET

This screen provides information regarding the hard disk.

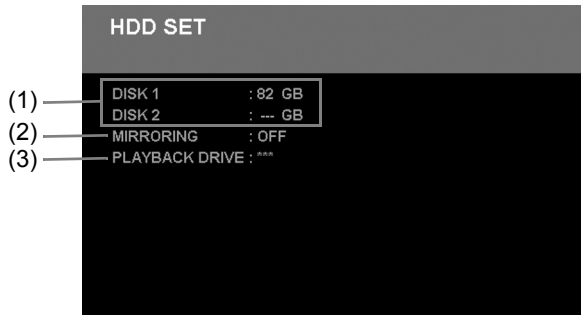

(1) Hard disk capacity

This item displays the total capacity of the hard disk. If hard disk expansion is carried out, a value will be displayed for each disk.

(2) MIRRORING

This item displays settings relevant to mirroring-type recording on the digital video recorder.

[Settings] (◆ indicates default setting.)

Setting	Description
ON	Mirroring recording is carried out.
◆OFF	Mirroring recording is not carried out.

NOTE

● Mirroring

When hard disk expansion has been carried out, the same video can be recorded to both hard disks in a process known as “mirroring”. Even if a problem occurs in the writing of video data to one of the disks, it will be possible to extract normal data from the other disk when this function is turned on.

(3) PLAYBACK DRIVE

This item indicates which of the hard drives will be used to provide video for playback when mirroring has been turned on.

[Settings] (◆ indicates default setting.)

Setting	Description
◆***	Mirroring is not carried out.
DISK1	Playback data is read from disk1.
DISK2	Playback data is read from disk2.

! CAUTION

- The “***” will be displayed for “PLAYBACK DRIVE” when only one hard disk is being used or when “MIRRORING” is set to “OFF”. Settings can not be made in these cases.
- When this setting is made after hard disk expansion, the hard disks will be initialized and all recorded video will be lost. If any important recordings are stored on the hard disks, they should be stored on a separate data storage device before making this setting.

13. NETWORK SET

Network settings must be made in advance on the unit whenever it is to be controlled via a network. Once this has been done, settings can then be changed from the controlling PC.

NOTE

● Changing network-related settings

When these settings are modified, connection will be canceled and control rights will be returned to the unit. To restore the connection, repeat network settings on the PC to match the modified unit settings.

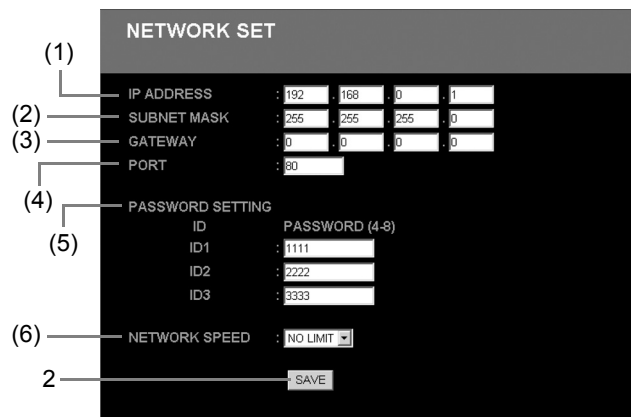

1 Change the settings as required.

Item	Description
(1) IP ADDRESS	Allows the unit's IP address to be modified.
(2) SUBNET MASK	Allows the unit's subnet mask to be modified.
(3) GATEWAY	Allows the unit's gateway to be modified.
(4) PORT	Allows the unit's port number to be modified. Set within the range of 1 to 65535. (default setting: 80)

NOTE

- If a value other than “80” is set as the default value for the port, when specifying the URL, enter a colon (:) and then the port number after the IP address.
For example, if the port number was set as “81”, you should enter
http://192.168.0.1:81/

CAUTION

- If settings are changed during network control, the connection will be terminated.

(5) PASSWORD SETTING

This item allows you to set a password for each different user level.

User level	1	2	3
User name	ID1	ID2	ID3
Usable menus	Monitoring of live images	<input type="radio"/>	<input type="radio"/>
	Monitoring and searching of recorded images	<input type="radio"/>	<input type="radio"/>
	Starting and stopping of recording; timer recording; modification of unit settings, etc.	<input type="radio"/>	<input type="radio"/>
Password (default setting)	1111	2222	3333

CAUTION

- Use between 4 and 8 alphanumeric characters for passwords.

(6) NETWORK SPEED

This item lets you modify the network speed setting. (Network speed cannot be set using the digital video recorder.)

NO LIMIT, 64, 128, 256, 512, or 1024 (kbps)

When the unit is reset, the network speed setting will revert to the default value (i.e., NO LIMIT).

2 Click [SAVE].

The network settings or modifications are saved.

14. RS-485 SET

This screen displays settings relevant to the unit's interfaces.

NOTE

- It will not be possible to modify settings: The screen displays data for confirmation purposes only.



	Item	Overview	Setting	Description
(1)	DATA SPEED	Displays the RS-485 communication speed.	2400/ 4800/ 9600/ 19200 (bps)	
(2)	STATUS INFO	Displays whether or not status information will be transmitted during RS-485 communication.	ON	Status information will be transmitted.
			OFF	Status information will not be transmitted.
(3)	ALARM INFO	Displays whether or not alarm information will be transmitted during RS-485 communication.	ON	Alarm information will be transmitted.
			OFF	Alarm information will not be transmitted.
(4)	ADDRESS	Displays the address when RS-485 has been selected.	0 to 127	Set within the range of 0 to 127.

15. MASK SET

Use the following procedure to set video from individual cameras to be masked by a gray pattern when it is not needed on a monitor screen.

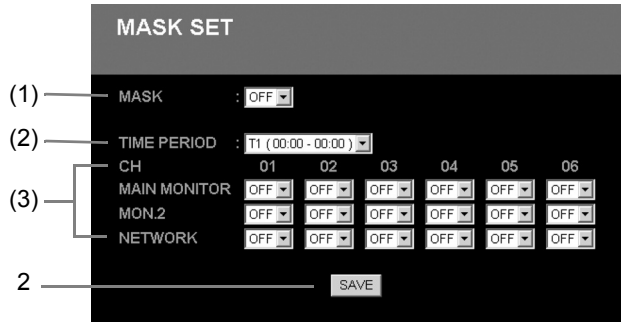

1 Set the following functions as required.

	Setting	Description
(1)	MASK	Turns masking on or off.
(2)	TIME PERIOD	Selects one of the time periods, T-1 through T-4.
(3)	CH	Turns each channel's masking on or off individually for the main monitor, the monitor 2, and network video.

2 Click [SAVE].

The setting is saved.

NOTE

- Network mask settings are valid only for the user connecting to the network with ID1. Users connecting using ID2 and ID3 will be able to display all channels.

16. POWER FAILURE/USED TIME

Check the date and time of power failures and the amount of hard disk usage as described below.

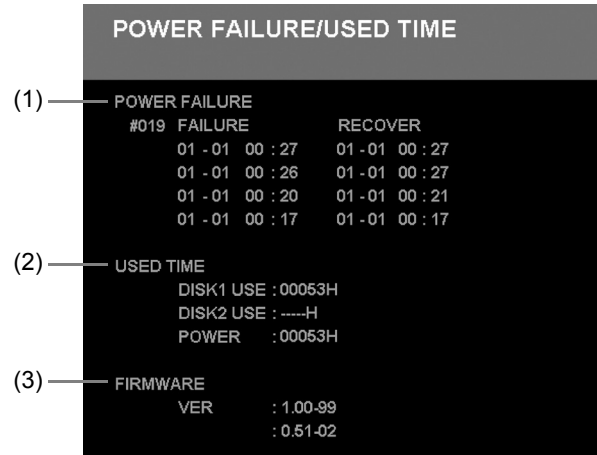

	Item	Description
(1)	POWER FAILURE	Displays the number of power failures and the date and time of occurrence and restoration for the four most recent power failures.
(2)	USED TIME	Displays the usage time for the digital video recorder. DISK1 USE: Total usage time for Disk 1 DISK2 USE: Total usage time for Disk 2 POWER: Total usage time for the unit
(3)	FIRMWARE	Displays the firmware version.

17. INITIALIZED RECORD

Check the records for hard-disk initialization and area resetting.

DATE	TIME	AREA
20 - 03	13 : 50	ALL AREAS(INITIALIZED)
20 - 03	11 : 27	ALL AREAS(INITIALIZED)
01 - 01	00 : 14	ALL AREAS(INITIALIZED)
01 - 01	00 : 14	NORMAL REC(AREA RESET)
01 - 01	00 : 12	ALL AREAS(INITIALIZED)
01 - 01	00 : 12	ALL AREAS(INITIALIZED)
01 - 01	00 : 11	NORMAL REC(AREA RESET)
01 - 01	02 : 42	NORMAL REC(AREA RESET)

	Item	Description
(1)	DATE	Displays the date of the operation.
(2)	TIME	Displays the time of the operation.
(3)	AREA	Displays the area in question and the corresponding operation content.

This section will describe the way in which monitored images and alarm images can be stored on the unit's internal hard disk.

Before any of these operations can be carried out, it will be necessary to make menu settings to match the installation environment. (→P. 10)



Normal recording

Monitored images can be recorded to the normal recording area by a manual operation.

- 1 Click the  button on the operation panel.

Normal recording starts.

Stopping normal recording

- 2 Click the  button on the operation panel.

Timer recording

Monitored images can be automatically recorded to the normal recording area in accordance with timer settings. Note that timer recording will not operate during normal recording.

- 1 Set the conditions for timer recording using the timer setting menu screen. (→P. 17)
- 2 Click the  button on the operation panel.

The unit will enter standby mode for timer recording, and recording will then start and stop automatically at the set times. The current condition for timer recording is displayed on-screen using the message "TIMER STANDBY" or "TIMER RECORDING".

NOTE

- If "OLY AL-RC ON TMR" has been selected using the "ALARM REC MODE SET" menu item (→P. 18), it will not be necessary to click the  button to setup standby mode.

Canceling timer recording

- 3 With "TIMER STANDBY" displayed, click the  button on the operation panel.

Alarm recording

When an alarm is detected by the alarm input terminal or a motion sensor, the recording of alarm images to the alarm recording area will start automatically.

Whenever alarm recording starts, normal recording, timer recording, and pre-alarm recording will be automatically terminated, and they will be automatically restarted as alarm recording ends.

- 1 Set the conditions for "ALARM RECORDING" using the "ALARM REC MODE SET" menu screen. (→P. 18)

- (1) Regardless of the unit's current operation or condition, alarm recording will be started automatically whenever an alarm is detected.
- (2) When the duration set for alarm recording has ended, alarm recording will be automatically stopped.

NOTE

- Settings can be made to have a buzzer sound on the PC when an alarm occurs on the digital video recorder. (→P. 21)

When the alarm sound stops during alarm recording, click the stop button on the operation panel.

Pre-alarm recording

Pre-alarm recording can be set to record video just before an alarm. It will be possible to view images from just before an alarm when alarm recording is being played back.

- 1 Set the conditions for "PRE-ALARM RECORDING" using the "ALARM REC MODE SET" menu screen. (→P. 19)

- (1) The newest images from the preset duration will be automatically recorded and updated by overwriting.
- (2) Pre-alarm recording will be automatically terminated whenever alarm recording starts, and it will be automatically restarted as alarm recording ends.

Screen display items

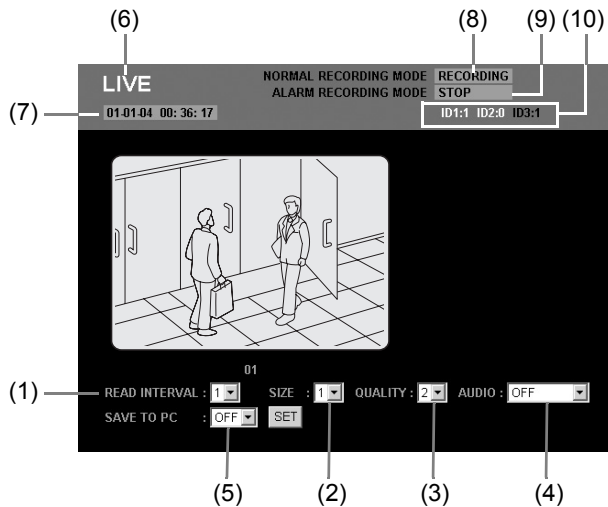

(1) READ INTERVAL (Default setting: 1)

This item allows you to select one of five image display speeds.

Larger setting numbers correspond to higher speeds; however, the actual speed will depend on the speed of your network connection.

* When "(4) AUDIO" is set to "ON", "READ INTERVAL" cannot be set.

(2) SIZE (Default setting: 1)

This item allows you to select one of six image sizes.

Larger setting numbers correspond to larger image sizes.

1	320 × 240	4	800 × 600
2	400 × 300	5	1,024 × 768
3	640 × 480	6	1,280 × 960

* Size for full screen monitoring.

(3) QUALITY (Default setting: 2)

This item allows you to select one of three picture quality settings for PC display. (Only live mode)

1	Lowest quality
2	Standard quality
3	Best quality

(4) AUDIO (Default setting: OFF)

Sound can be played in live mode or play mode.

* Set only for full screen monitoring.

[Settings]

Setting	Description
OFF	Audio will not be played.
ON-5SEC ON-10SEC ON-15SEC ON-20SEC ON-30SEC	Audio will be played. Set the audio delay (5, 10, 15, 20, or 30 seconds). In Play mode, the speed of fast-forward and frame advance may be affected by the network environment being used. In addition, if the audio-data reading screen appears frequently, the audio delay (5, 10, 15, 20, or 30 seconds) should be made longer to match the network environment. If this screen continues to appear frequently even when the delay time is 30 seconds, it indicates that audio playback is not possible with the network environment being used.
	<p>* Audio delay</p> <p>The delay time prevents sound dropouts and the loss of synchrony between video and sound.</p>

(5) SAVE TO PC (Default setting: OFF)

When this is set to "ON", live images or playback images can be saved on a PC.

* Size for full screen monitoring.

! CAUTION

- A user level of ID2 or better is required for the playing back and saving to PC.
- When audio is to be played back, store the audio on the PC, install "DVR Viewer" for playback (→P. 2), and then set audio recording to "ON".
- Playback will be performed with priority given to audio, and as a result, images may not be displayed for certain hardware and software configurations.
- Audio playback is not possible for multi-screen display.

(6) Image mode

LIVE: Live mode

PLAY: Play mode

(7) Time

Live mode: Displays the current time

Play mode: Displays the recording time

(8) NORMAL RECORDING MODE

This item displays the current condition for normal recording.

- STOP
- RECORDING
- TIMER STANDBY
- TIMER RECORDING
- AREA FULL (in normal recording area)

(9) ALARM RECORDING MODE

This item displays the current condition for alarm recording.

- STOP
- PRE ALARM RECORDING
- ALARM RECORDING
- AREA FULL (in alarm recording area)

(10) Connection user

In situations where a number of different users are connected, this item displays the connection condition for the various user levels.

Typical display: ID1: 3 ID2: 1 ID3: 0

The user ID for the current user is displayed in red.

2 WATCHING IMAGES

Monitored live images and recorded images can be viewed freely and whenever so required.

Note that switching to live or playback images, modifying the screen display, and other similar operations have absolutely no effect on timer recording and alarm recording.

Watching live images during playback

Click the  (Playback stop) button on the operation panel. When playback has finished, the screen will switch back to the display of monitored live images.

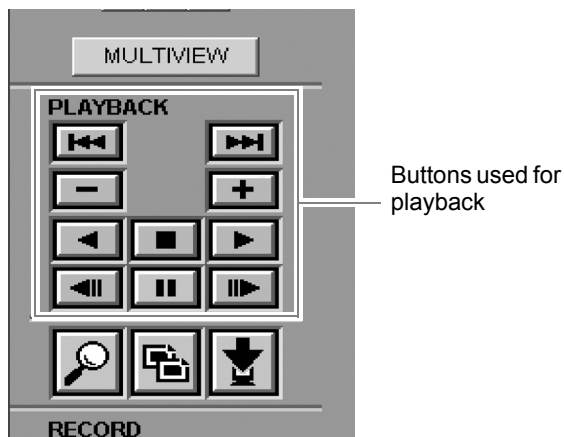

Playing back recorded images

The following two methods are available for the playback of images.

Image specification	Replay method
When no images are specified for replay	<p>Click the  button on the operation panel to switch to play mode and commence the playback of images from the normal recording area and the alarm recording area in the sequence in which they were recorded.</p> <ul style="list-style-type: none"> When recorded images are played back for the first time or when a reset is performed from the unit, playback will start from the beginning of the stored data. Any subsequent playback will start at the last stop point.
When images are specified for replay	<ul style="list-style-type: none"> The search function can be used to find the required images from the data stored in the hard disk's various recording areas. When the image for playback has been identified using search mode, the play mode screen will be automatically called up and the specified image will be played. For more details, see "3. SEARCH MODE" (→P. 33).

! CAUTION

Interference may appear on images or the playback may seem to have paused during the following operations; however, this is normal and no cause for concern.

- When the images from the normal recording area and the alarm recording area are played back in succession, the quality of the picture may drop momentarily as playback switches from one recording area to another.
- If normal, fast-forward, or fast-rewind playback is carried out either for playback during alarm recording or continuous playback from the normal recording area and alarm recording area, the image may seem to have paused in certain cases.

Specifying the number of screens to display

When a number of cameras are connected to the digital video recorder, it is possible to monitor video from several of these in multi-screen format. Use the following procedures to specify the channel numbers for the cameras to be displayed and the number of screens.

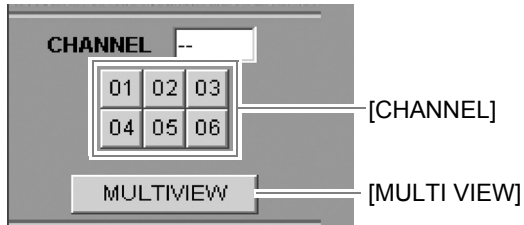

Viewing on a full screen

Click a [CHANNEL].

Click the button for the camera to be monitored. The video from the specified channel will be displayed on the full screen, and the corresponding number will be displayed in the "CHANNEL" box.

Viewing on a multi 6 screen

Press the [MULTI VIEW] button.

Video from all recording and recorded cameras will be displayed on a screen divided into six individual portions.

■ To resume full screen monitoring

Either click a [CHANNEL] button or double click one of the multiple screens being displayed to resume single-screen monitoring.

NOTE

- Video from each screen of the multi-screen will be updated at a speed appropriate for its channel. In addition, network conditions will also affect the updating speed.

Performing operations in play mode



Playback

Click the button.

Adjusting the playback speed

During playback, click the or button.

: Increases the playback speed.

: Reduces the playback speed.

Reverse playback

Click the button.

Adjusting the reverse playback speed

During reverse playback, click the or button.

: Increases the reverse playback speed.

: Reduces the reverse playback speed.

Still image

During playback, click the button.

Playback will be paused on the current image.

To return to normal play mode, click the button while playback is paused.

Frame advance (forward/reverse)

While playback is paused, click the or button.

: Advances a frame in the forward direction.

: Advances a frame in the reverse direction.

Alarm skip

During playback, click the or button.

The previous or next alarm image is displayed accordingly.

: Skips to the next alarm video.

: Skips to the previous alarm video.

Stopping playback

During playback, click the (Playback stop) button.

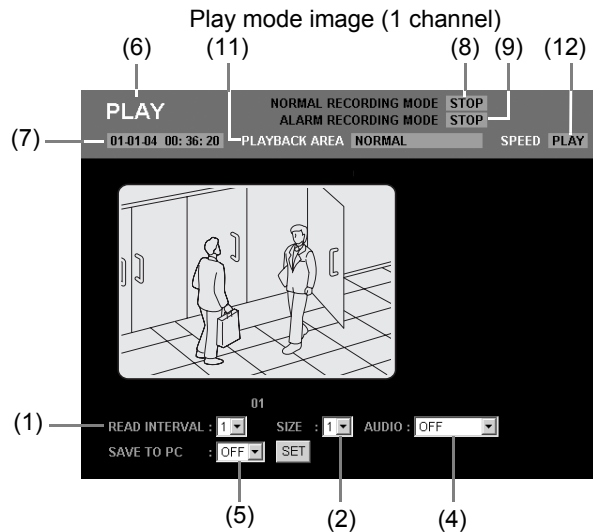
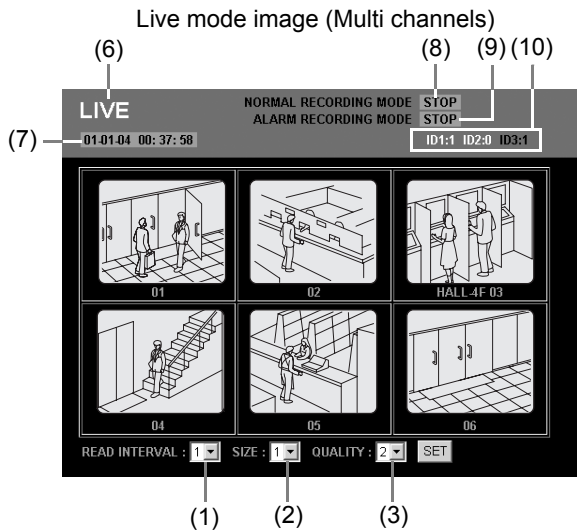

Adjusting the image and audio

The images displayed on screen can be adjusted in a number of ways.

To make an adjustment, select the adjustment value from the menu and then click [SET] from the pull-down menu on the screen.

(1) READ INTERVAL (Default setting: 1)

This item allows you to select one of five image display speeds.

Larger setting numbers correspond to higher speeds; however, the actual speed will depend on the speed of your network connection.

* When "(4) AUDIO" is set to "ON", "READ INTERVAL" cannot be set.

(2) SIZE (Default setting: 1)

This item allows you to select one of six image sizes.

Larger setting numbers correspond to larger image sizes.

1	320 × 240	4	800 × 600
2	400 × 300	5	1,024 × 768
3	640 × 480	6	1,280 × 960

* Size for full screen monitoring.

(3) QUALITY (Default setting: 2)

This item allows you to select one of three picture quality settings for PC display. (Only live mode)

1	Lowest quality
2	Standard quality
3	Best quality

(4) AUDIO (Default setting: OFF)

Sound can be played in live mode or play mode.

* Set only for full screen monitoring.

[Settings]

Setting	Description
OFF	Audio will not be played.
ON-5SEC ON-10SEC ON-15SEC ON-20SEC ON-30SEC	Audio will be played. Set the audio delay (5, 10, 15, 20, or 30 seconds). In Play mode, the speed of fast-forward and frame advance may be affected by the network environment being used. In addition, if the audio-data reading screen appears frequently, the audio delay (5, 10, 15, 20, or 30 seconds) should be made longer to match the network environment. If this screen continues to appear frequently even when the delay time is 30 seconds, it indicates that audio playback is not possible with the network environment being used. * Audio delay The delay time prevents sound dropouts and the loss of synchrony between video and sound.

(5) SAVE TO PC (Default setting: OFF)

When this is set to "ON", live images or playback images can be saved on a PC.

* Set only for full screen monitoring.

CAUTION

- A user level of ID2 or better is required for the playing back and saving to PC.
- When audio is to be played back, store the audio on the PC, install "DVR Viewer" for playback (→P. 2), and then set audio recording to "ON".
- Playback will be performed with priority given to audio, and as a result, images may not be displayed for certain hardware and software configurations.
- Audio playback is not possible for multi-screen displays.
- In the case of certain PC performance levels and specifications, a portion of the video may not be displayed. If this is the case, go to [Tools] → [Internet Options] → [Temporary Internet Files] → [Settings] in Internet Explorer, and then reduce "Amount of disk space to use".

Screen display items

(6) Image mode

LIVE: Live mode

PLAY: Play mode

(7) Time

Live mode: Displays the current time

Play mode: Displays the recording time

(8) NORMAL RECORDING MODE

This item displays the current condition for normal recording.

- STOP
- RECORDING
- TIMER STANDBY
- TIMER RECORDING
- AREA FULL (in normal recording area)

(9) ALARM RECORDING MODE

This item displays the current condition for alarm recording.

- STOP
- PRE ALARM RECORDING
- ALARM RECORDING
- AREA FULL (in alarm recording area)

(10) Connection user

In situations where a number of different users are connected, this item displays the connection condition for the various user levels.

Typical display: ID1: 3 ID2: 1 ID3: 0

The user ID for the current user is displayed in red.

(11) PLAYBACK AREA (in the play mode screen only)

This item displays the recording area for the current playback image

- ALARM
- PRE-ALARM
- NORMAL
- ARCHIVE

(12) SPEED (in the play mode screen only)

This item displays the playback speed and direction.

Display	Playback direction	Playback speed
PLAY	Forward	Normal
STILL	Still	Still
R.PLAY	Reverse	Normal
CUE	Forward	Fast-forward playback
REVIEW	Reverse	Fast-rewind playback
SLOW	Forward	Slow playback
R.SLOW	Reverse	Slow reverse playback

Settings for downloading live images to a PC

! CAUTION

- If video with audio is to be downloaded to a PC, DVR Viewer must be installed before the necessary settings can be made. (→P. 2)

1 Live images will be displayed when connected with user level ID2 or ID3.

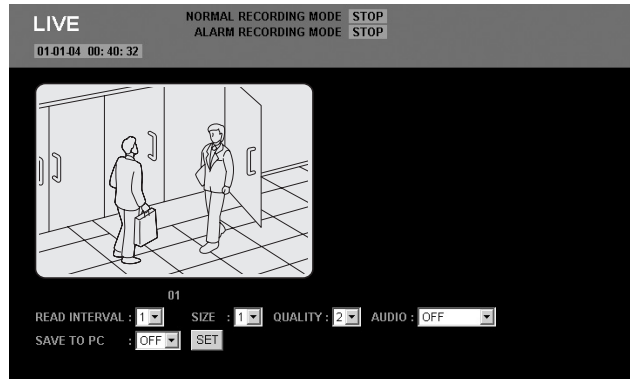

2 Set "SAVE TO PC" to "ON" and then click [SET].

The save setting items are displayed.

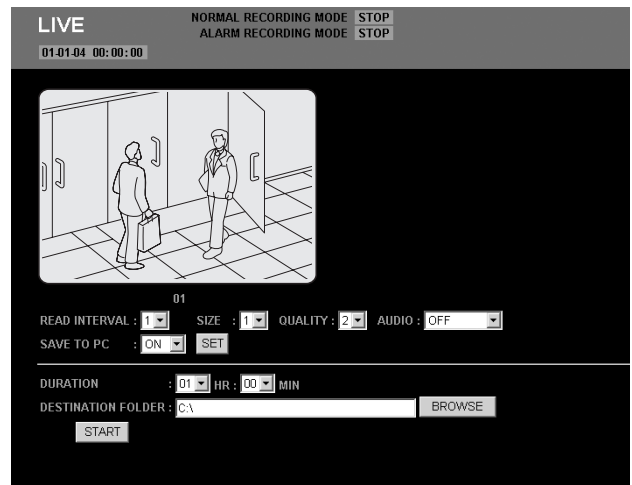

3 Set "DURATION".

The duration for images to be saved to the PC should be set in units of one minute.

4 Click [BROWSE].

A dialog box for selecting save location will be displayed, and a suitable location should be set.

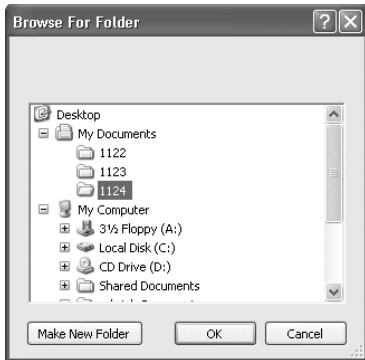

NOTE

- It is also acceptable to input a location for saving directly into "DESTINATION FOLDER".

5 Click [OK].

The setting menu will close and the screen will return to the condition for procedure 2 above. The "DESTINATION FOLDER" location is displayed.

6 Click [START].

- The saving process begins. The elapsed save time and the current save image are displayed on screen. The elapsed save time will be incremented as the save progresses.

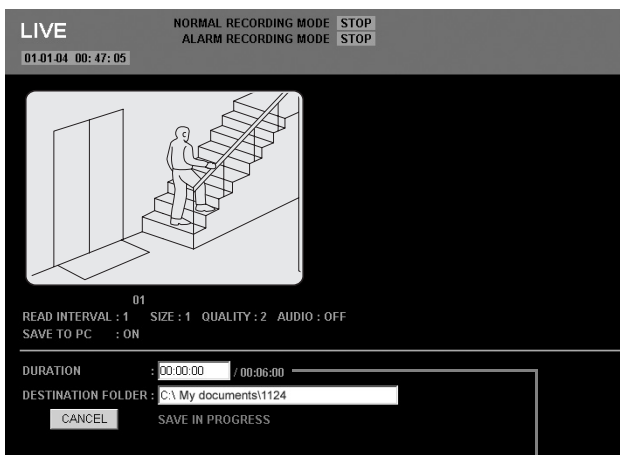

Elapsed save time

■ To cancel a save operation

Click [CANCEL].

- A pop-up window will be displayed when saving has been completed. The final still image from the save process will be displayed.

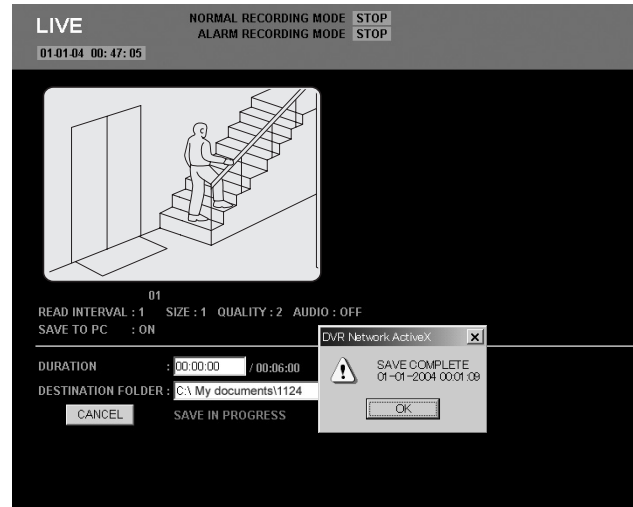

7 Click [OK] in the pop-up window.

The setting menu will close and the screen returns to the condition for procedure 2 above.

Folders as shown below will be created within the folder set in procedure 4, and within these folders, images are stored with numbers assigned automatically.

```

DVR00001— IMG00001 — 000001.JPG
                   (1)   (2)   000002.JPG
                   |       000003.JPG

DVR00002— IMG00001 — 000001.JPG
                   |       000002.JPG
                   |       000003.JPG
  
```

- The folder "DVR00001" is created.
- Within this folder, folders are created in sequence starting with "IMG00001". Images are stored in each folder.

Images stored in the recording areas can be searched and played back in search mode. Furthermore, five different search methods are available for doing so.

Basic operation

- 1 In live mode (When playback is stopped), click the  button on the operation panel.**

The SEARCH screen is displayed.

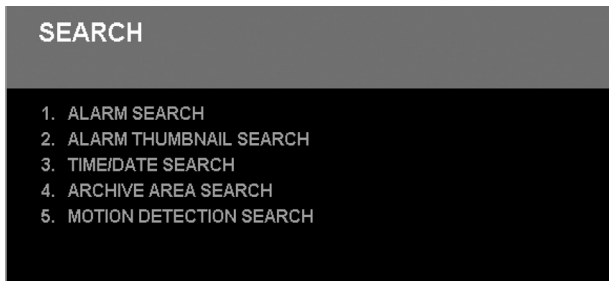

- 2 Select and click the desired search mode from the SEARCH screen.**

The screen for the selected search mode is displayed.

- 3 Search for images using the search mode screen.**

See the following pages for more details regarding the different search procedures.

- 4 Check the returned images using the preview or thumbnail display and then click the screen.**

Play mode will be activated and the playback of the full image will start. See "Performing operations in play mode" (→P. 29) for more details regarding still image, fast-forward, and other similar operations.

Search menu

	Search mode	Recording area for searching	Description
1	ALARM SEARCH	Alarm recording area	Lets you search and play back alarm images from the alarm event list.
2	ALARM THUMBNAIL SEARCH	Alarm recording area	Lets you search and play back alarm images using thumbnails.
3	TIME/DATE SEARCH	Normal recording area and alarm recording area	Lets you search and play back recorded images by date/time.
4	ARCHIVE AREA SEARCH	Archive area	Lets you search and play back images stored (or copied) to the archive area using an image list.
5	MOTION DETECTION SEARCH	Normal recording area and alarm recording area	Lets you search and play back recorded images of moving objects detected in accordance with motion sensor settings.

CAUTION

- If the normal recording area is "*0%", it will not be possible to select "ALARM SEARCH", "ALARM THUMBNAIL SEARCH", or "MOTION DETECTION SEARCH".

1. ALARM SEARCH

In alarm search mode, images recorded in the alarm recording area are presented as a list of alarm numbers. Accordingly, alarm images from the recording list can be searched and played back.

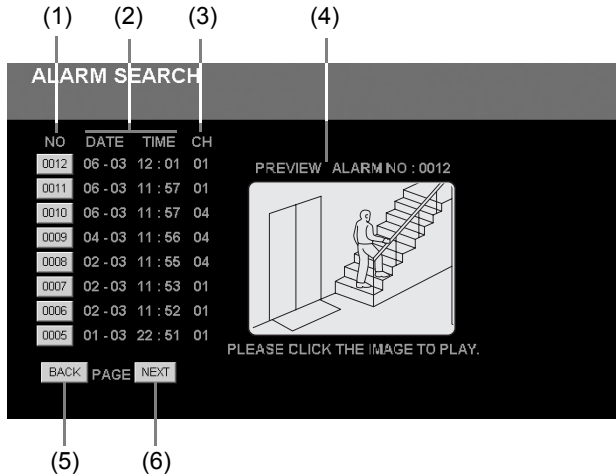

- (1) NO: Alarm number
- (2) DATE/TIME: Recording date and time
- (3) CH: Displays the channel on which alarm recording was performed
- (4) PREVIEW: Displays a preview of alarm images
- (5) [BACK]: Displays a list of the previous 8 images
- (6) [NEXT]: Displays a list of the subsequent 8 images

1 Select "1. ALARM SEARCH" from the SEARCH menu.

An alarm event list is displayed in the ALARM SEARCH screen with newer recordings displayed first.

2 Select the alarm number to be played back from the alarm event list.

- Clicking an alarm No. button displays a preview of the corresponding alarm image.
- A maximum of 8 alarm events can be displayed on a single screen.
- Click [BACK] or [NEXT] to display the alarm event list for the previous or subsequent 8 events accordingly.

3 Click the preview screen for the image to be played back.

Full-screen playback will start from the point at which the alarm was triggered.

2. ALARM THUMBNAIL SEARCH

In alarm thumbnail search mode, all of the alarm images stored in the alarm recording area are displayed as thumbnails. Accordingly, you can search and play back alarm images using their thumbnails.

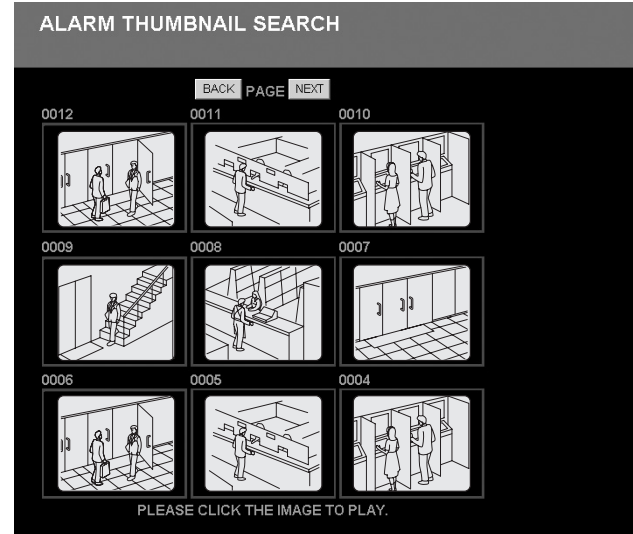

1 Select "2. ALARM THUMBNAIL SEARCH" from the SEARCH menu.

- The newest alarm images with attached alarm numbers are displayed in chronological order in the ALARM THUMBNAIL SEARCH screen.
- A maximum of 9 alarm events can be displayed as thumbnails on a single screen.
- Click [BACK] or [NEXT] to display the thumbnail screen for the previous or subsequent 9 events accordingly.

2 Click the thumbnail for the image to be played back.

Full-screen playback will start from the point at which the alarm was triggered.

3. TIME/DATE SEARCH

In date/time search mode, images from the normal recording area or the alarm recording area can be played back by specifying the corresponding date and time.

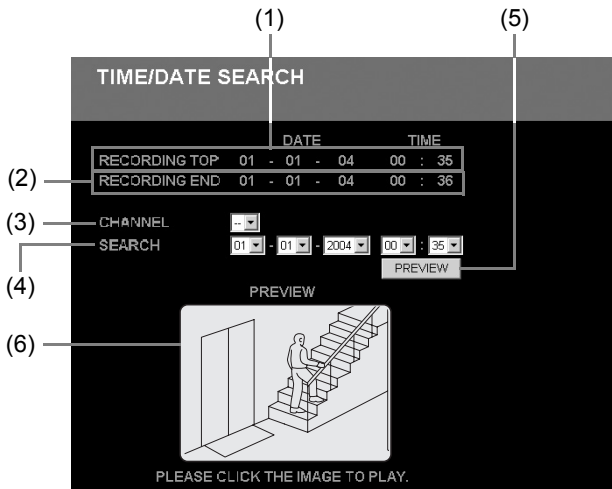

- (1) RECORDING TOP: Displays the date and time of the oldest recording
- (2) RECORDING END: Displays the date and time of the newest recording
- (3) CHANNEL: Displays the channel (or camera number)
- (4) SEARCH: Used to set the recording date and time of the image to be played back
- (5) [PREVIEW]: Used to indicate preview display
- (6) PREVIEW: Displays a preview of the image corresponding to the specified date and time

1 Select "3. TIME/DATE SEARCH" from the SEARCH menu.

The TIME/DATE SEARCH screen is displayed.

2 Specify the channel or camera number from "CHANNEL" pull-down menu.

If only one channel is available, "--" will be displayed.

3 Specify the recording date and time for the image to be played back from "SEARCH" pull-down menu.

Day/Month/Year/Hours/Minutes

4 Click [PREVIEW].

When the search has been completed, the image corresponding to the specified date and time will be played back.

NOTE

- If no image exists for the specified date and time, the image with the nearest recording date and time will be displayed.

5 Click the preview screen for the image to be played back.

Full-screen playback will start.

4. ARCHIVE AREA SEARCH

In archive area search mode, you can play back recorded images stored (or copied) to the archive area.

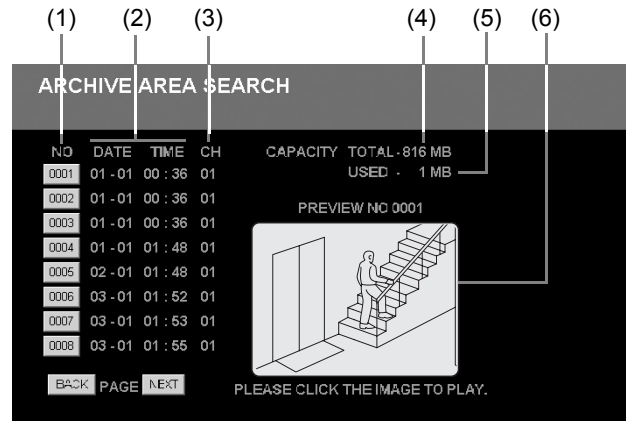

- (1) NO: Image number
- (2) DATE/TIME: Recording date and time
- (3) CH: Displays the channel on which recording was performed.
- (4) CAPACITY TOTAL: Total capacity of the archive area
- (5) CAPACITY USED: Amount of archive area capacity currently storing data
- (6) PREVIEW: Displays a preview of the recorded image

1 Select "4. ARCHIVE AREA SEARCH" from the SEARCH menu.

The search screen for the archive area is displayed.

This screen contains a list of stored images displayed in sequence from the earliest item.

2 Select the image number to be played back from the stored image list.

- A preview of the corresponding stored image is displayed.
- A maximum of 8 stored images can be displayed on a single screen.
- Click [BACK] or [NEXT] to display the image list for the previous or subsequent 8 images accordingly.

3 Click the preview screen for the image to be played back.

Full-screen playback will start.

5. MOTION DETECTION SEARCH

By setting images recorded in the hard disk's normal recording area or alarm recording area to the motion sensor, variations from these images as a result of the presence of an intruder or the like can be detected, and the corresponding images can be played back.

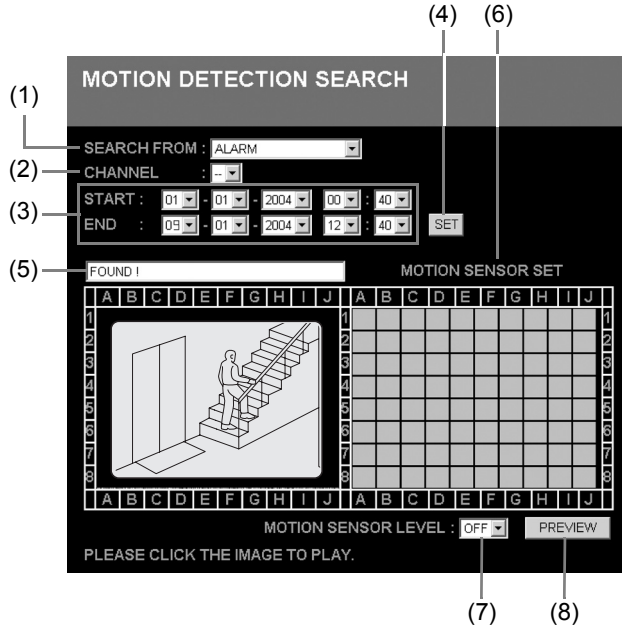

(1) SEARCH FROM

The recording area to be used for motion searching

(2) CHANNEL

The channel or camera number to be used for motion searching

(3) START/END

The date and time of the start and end of the memory area for motion searching

(4) [SET]

Detection condition settings

(5) Message box

This box displays the results of searching for motion-detection images

When searching	"SEARCHING"
When motion-detection images exist	"FOUND!"
When motion-detection images do not exist	"IMAGES NOT FOUND!"

(6) MOTION SENSOR SET

Screen for making motion sensor settings

(7) MOTION SENSOR LEVEL

Motion sensor sensitivity setting: OFF or 1 through 10 (Lower numbers correspond to higher levels of sensitivity.)

(8) [PREVIEW]

Displays a preview of the detection image

1 Select "5. MOTION DETECTION SEARCH" from the SEARCH menu.

The motion detection search screen is displayed.

2 Specify the recording area to be used for motion searching from "SEARCH FROM" pull-down menu.

[Settings] (◆ indicates default setting.)

Setting	Description
◆ALARM	Searching will only be performed for images in the alarm recording area.
NORMAL	Searching will only be performed for images in the normal recording area.
ALARM AND NORMAL	Searching will be performed for images in the alarm recording area and normal recording area.

3 Specify the channel (or camera number) for searching from "CHANNEL" pull-down menu.

If the number of channels is one, "-" will be displayed here.

4 Click [SET].

The date and time of the start and end of recording of motion detection images is displayed in "START" and "END" respectively.

NOTE

- Use "START" and "END" to make new date and time settings when the searching range is to be reduced.
- The results of searching will be displayed in a message box when [SET] is clicked.

5 Setting motion sensor detection conditions.

• Motion sensor positions

The motion sensor setting screen shows an 8 x 10 (height x width) grid of sensors, and when one of these sensors is clicked, the corresponding sensor setting mark will turn red. If the same location in the grid is clicked once again, the motion sensor will be deselected.

• Motion sensor sensitivity

Lower numbers correspond to higher levels of sensitivity, and a setting should be made from the pull-down menu.

6 Click [PREVIEW].

A search is carried out within the specified area for images in which motion was detected, and these images are then listed in recording sequence in the preview screen.

7 Click the preview screen for the image to be played back.

Full-screen playback will start.

You can use the procedures described below to copy recorded images to the hard disk's archive area or to download images to a PC or the like.

These functions should be used to backup important images from the normal recording area and the alarm recording area.

NOTE

- Copied data is stored one image at a time. Moving images can be copied by setting the number of images required from the first copied image.
- In a single copy operation, a maximum of 10,000 images can be copied to the archive area and a maximum of 1,000 images can be downloaded to a PC.

CAUTION

- In certain cases where network-busy is detected as a result of hardware conditions, the network may be forcibly disconnected in order to protect DVR recording operations. Furthermore, the network will be forcibly disconnected in response to a command to send a large amount of data in a single operation (in particular, when 100 images or more are to be saved), and in such a case, a limit should be applied to the number of images based on the hardware configuration in question.
- When the archive area becomes full of images, these images are to be downloaded to a CompactFlash card or the like, and [AREA FULL RESET] from the recording area settings on the MAIN MENU should be clicked. (→P. 13)
- Saving is only possible during full-screen display and not when multi-screen display is used.

Copying to the archive area

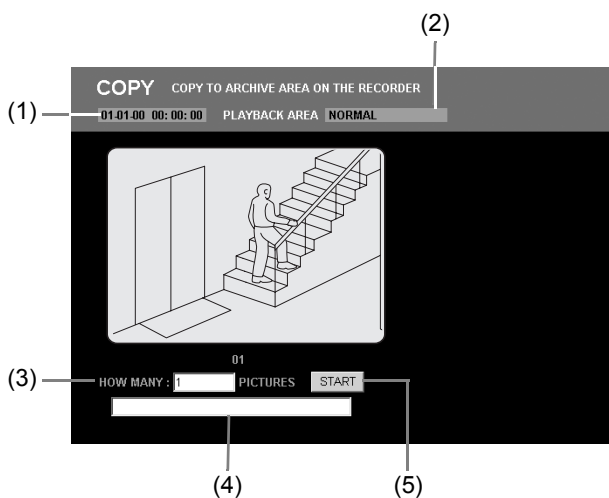

- (1) Recording date/time: The recording date and time for the image currently being played back
- (2) PLAYBACK AREA: The area in which the image currently being played back is recorded
 - NORMAL
 - ALARM
- (3) HOW MANY: Setting for the number of images to be stored
- (4) Message box: Displays the state of progress for copying
- (5) [START]: Starts copying

1 Play an image from the normal recording area or the alarm recording area.

2 Click the  button at the start of the image to be copied.

Playback of the image is paused.

3 Click the  button on the operation panel.

The COPY screen is displayed.

4 Input the number of images into "HOW MANY".

Specifically, indicate the number of images after the start image to be copied in succession.

Setting range: 1 to 10,000

A warning message will be displayed if an invalid number is entered here.

5 Click [START].

Copying to the archive area will begin and the message box will display the current state of progress.

[Settings]

Setting	Description
Copying	"COPYING TO ARCHIVE AREA!"
Copying completed	"COPY FINISHED!"

CAUTION

- The COPY screen cannot be displayed when playing video from the archive area.

6 When copying has been completed, click the  button to display live video or the  button to display playback video.

Downloading to a PC

Use the following procedure to download recorded images to a PC.

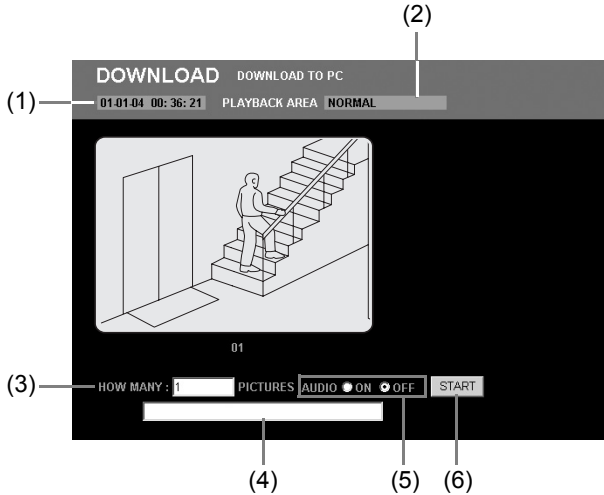

- (1) Recording date/time: The recording date and time for the image currently being played back
- (2) PLAYBACK AREA:
The area in which the image currently being played back is recorded
 - NORMAL
 - ALARM
 - ARCHIVE
- (3) HOW MANY: Setting for the number of images to be stored
- (4) Message box: Displays the state of progress for downloading
- (5) AUDIO: Setting for audio
- (6) [START]: Starts downloading

1 Play a recorded image.

2 Click the button when the image to be downloaded is being played back.

Playback of the image is paused.

NOTE

- All images from the normal recording area, alarm recording area, and archive area can be selected for downloading.

3 Click the button on the operation panel.

The DOWNLOAD screen is displayed.

4 Input the number of images into “HOW MANY”.

Specifically, indicate the number of images after the start image to be downloaded in succession.

Setting range: 1 to 1000

A warning message will be displayed if an invalid number is entered here.

! CAUTION

- Due to Internet Explorer limitations, the number of images to download must be set so that all downloads will be completed within approximately 5 minutes.

5 Select the “AUDIO”.

[Settings] (◆ indicates default setting.)

Setting	Description
ON	Image audio will be copied.
◆OFF	Audio will not be copied.

! CAUTION

- Audio cannot be selected when downloading from the archive area.

6 Click [START].

Downloading will start and the message box will display “PLEASE WAIT!”.

When all of the specified images have been downloaded, the image viewer screen will be called up and you will be prompted to confirm that the corresponding data is to be saved.



7 Click [OK].

8 Specify a location for storing the data.

■ If storing only video;

Select [Save As...] from the Internet Explorer [File] menu, specify the storage location and file name in the [Web Page] dialog box, and then click the [Save] button.

■ If storing video and audio;

Click the [SAVE WITH AUDIO] button, specify the storage location and file name in the [SAVE WITH AUDIO] dialog box, and click the [SAVE] button. A confirmation box will be displayed when saving has been completed, and [OK] should be clicked here.

! CAUTION

- Internet Explorer 5.0 or later must be used: Saving of images will not be possible with earlier versions or other browsers.
- A time restriction of approximately 2 minutes is applied to the downloading of audio data, and for this reason, downloading may not be possible when there are a large number of images.

* Image viewer screen

This screen allows you to check images that have been downloaded.

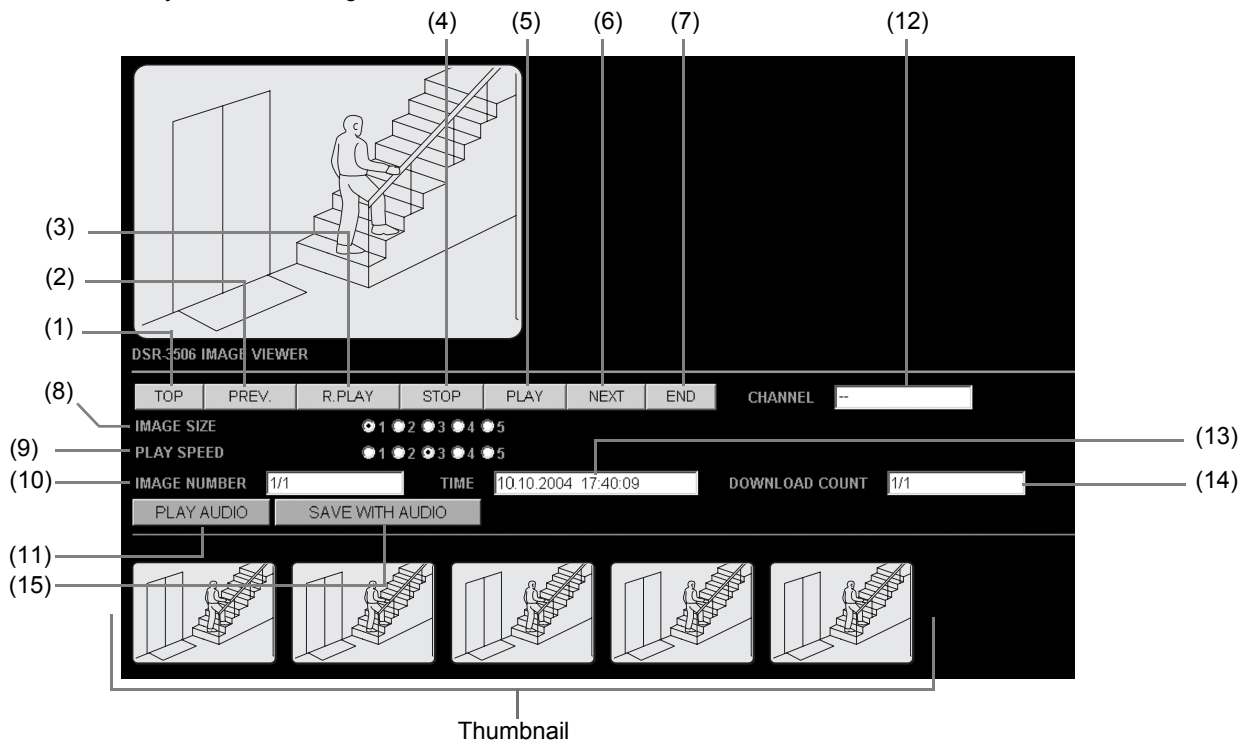

(1) [TOP]

Displays the first image.

(2) [PREV.]

Moves to the previous image.

(3) [R.PLAY]

Starts reverse playback. When the first image is reached, reverse playback will automatically continue from the last image.

(4) [STOP]

Stops playback.

(5) [PLAY]

Starts playback. When the last image is reached, playback will automatically continue from the first image.

(6) [NEXT]

Moves to the next image.

(7) [END]

Displays the last image.

(8) IMAGE SIZE

Sets the size of the display image.

1	400 × 300	4	1,024 × 768
2	640 × 480	5	1,280 × 960
3	800 × 600		

(9) PLAY SPEED

Sets the playback speed.

1	1 sec	4	0.125 sec
2	0.5 sec	5	0.05 sec
3	0.25 sec		

* The playback speed values will depend on the computing power of the PC being used.

(10) IMAGE NUMBER

Displays the number of the image currently being played back.

(11) [PLAY AUDIO]

Plays back the audio (you can also play back both audio and image on the screen).

(12) CHANNEL

Displays the download channel (or camera number).

(13) TIME

Displays the recording date and time for the image currently being played back.

(14) DOWNLOAD COUNT

Displays the download progress in the form of "image currently being downloaded/total number of images to be downloaded". (If recording do not exist for all entered images, the overall number will be restricted to the recorded number.)

(15) [SAVE WITH AUDIO]

Saves both the image and audio.

NOTE

- Windows Media Player must be installed in order to playback audio using Image Viewer.
- Audio and video may not synchronize in Image Viewer. If it is important that audio and video be in perfect synchrony, DVR Viewer should be used for playback.

The DVR Viewer is a program designed specifically for DVRs. It can be used to play back image and sound data that has been copied onto media such as computer hard disk drives, CompactFlash cards.

The DVR Viewer can be downloaded from the Sanyo website at the URL given below.

Sanyo website URL:

<http://www.sanyosecurity.com>

! CAUTION

- When playing back sound data, you will need Version 1.5 or later.

Operating environment

The following operating environment is required in order to use the DVR Viewer.

- Applicable operating system: Windows 98, 98SE, Me, NT4.0, 2000, XP
- Applicable computer: PC/AT compatible computer running one of the above operating systems

NOTE

- If an older version of DVR Viewer or ActiveX is installed, remove them from [Control Panel] → [Add or Remove Programs] in advance.

Installing the DVR Viewer

Install the DVR Viewer by the following procedure.

1 Starting the installation wizard

Double-click the icon for the downloaded "Setup.exe" file to start the installation wizard.



2 Selecting the language settings

Select the display language for the software (English) in the [Choose Setup Language] window and then click [OK].



3 Starting the installation

Click [Next>] in the [Welcome to the InstallShield Wizard for DVR Viewer] window to start the installation process.

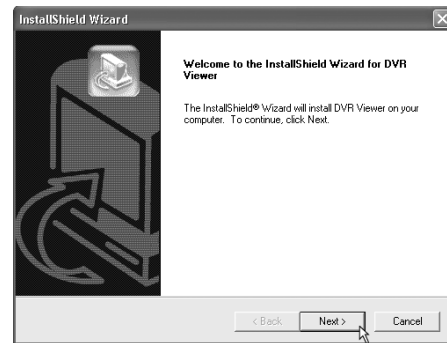

4 Choosing the destination location

Check that the destination folder shown in the [Choose Destination Location] window is correct, and then click [Next>].

If you would like to change the folder, click [Browse...] and specify the desired folder.

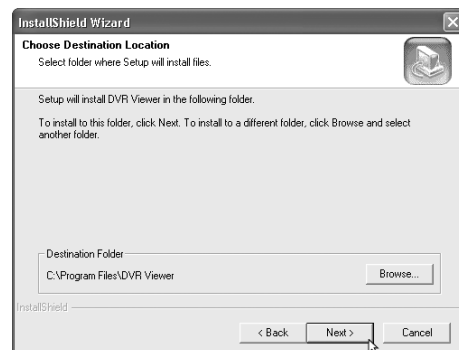

5 Starting copying of files

Check that all the settings shown are correct, and then click [Next>]. Copying of files will then start. If you would like to change any of the settings, click [<Back].

6 Completion of installation

When the installation is complete, the [Maintenance Complete] window appears. Click [Finish].



Opening and closing DVR Viewer

Opening DVR Viewer

From the Start menu, select [Programs] → [DVR Viewer] → [DVR Viewer] in the sequence to start the program.

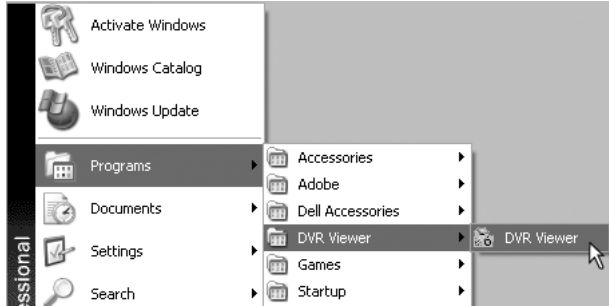

When DVR Viewer starts up, the following default window appears.

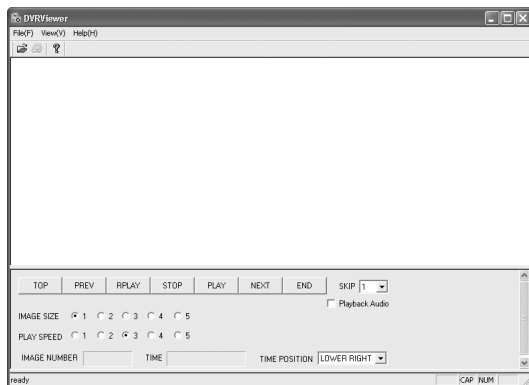

NOTE

- If you create a shortcut icon for DVR Viewer on the desktop, you can open DVR Viewer quickly by double-clicking the shortcut icon.
To create a shortcut icon, right-click [Programs] → [DVR Viewer] → [DVR Viewer] in the Start menu, drag the name to a spare place on the desktop, and select [Copy Here].

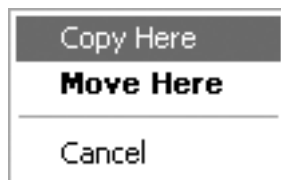

Closing DVR Viewer

Click the close button in the top-right corner of the program window, or select [Exit (X)] from the [File (F)] menu to close DVR Viewer.

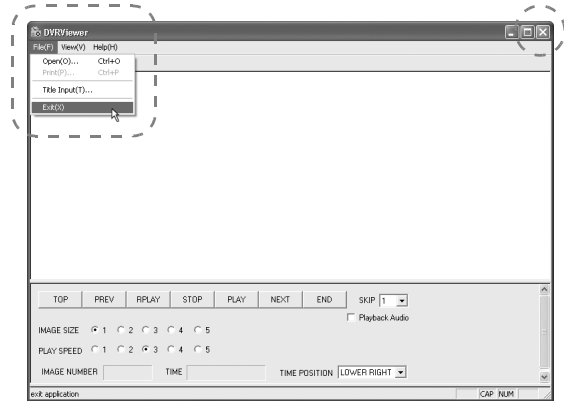

Menu structure

The basic menus for DVR Viewer are located on the menu bar and tool bar in the upper-left of the window. Click a command to open the corresponding menu.

Menu bar

This is the basic menu for DVR Viewer. Click a command to view the details for that command.

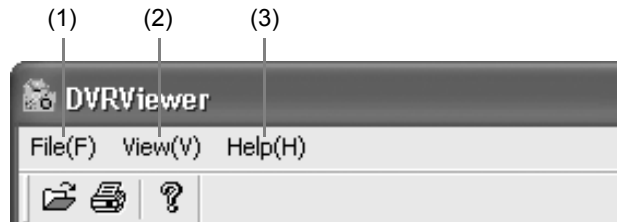

(1) File (F)

Open (O): Displays the Open file dialog box.

Print (P): Prints the specified file.

Title Input (T): Displays the dialog box for entering titles for printed images.

Exit (X): Closes DVR Viewer.

(2) View (V)

Toolbar (T): Displays and hides the toolbar.

Status bar (S): Displays and hides the status bar at the bottom of the window.

Separate (P): Moves the boundary line at the bottom of the window up and down.

Date Display Format (D): Sets the date display format.

(3) Help (H)

Displays the version information for the DVR Viewer that is currently open.

Toolbar

This contains commands that are most often used.

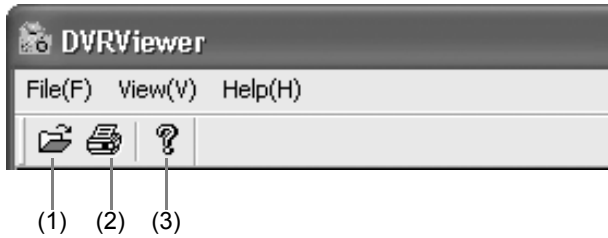

- (1) Corresponds to the [Open (O)] command in the [File (F)] menu.
- (2) Corresponds to the [Print (P)] command in the [File (F)] menu.
- (3) Corresponds to the [Help (H)] command.

Opening files

When DVR Viewer is opened, you can open files to be played back by the following procedure.

1 Click [Open (O)] in the [File (F)] menu.

Alternatively, click the  icon on the toolbar.

2 Specify the drive and folder containing the file to be opened.

In the [Open] dialog box, use the radio buttons to select one of the following two options depending on the type of media that contains the image data.

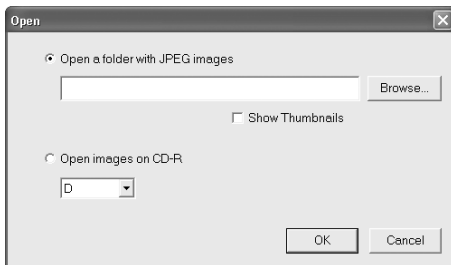

(1) Open a folder with JPEG images

Select this option if you would like to open JPEG images that have been copied from a DVR to a CompactFlash card or that have been downloaded to the computer over a network.

Click [Browse...] to display the folder tree. Specify the folder to be viewed and then click [OK].

If you would like thumbnail images to appear, check [Show Thumbnails].

! CAUTION

- To play back sound, be sure to specify a folder that contains "WAV" files.
- This digital video recorder does not support the "Open images on CD-R" option in the dialog box.

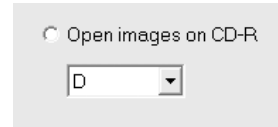

To open images on a CD-R, select the CD-R drive name in question using the "Open a folder with JPEG images" in the dialog box.

Viewing images

When image files are opened, the images that have been loaded appear. The display window consists of a main window and a thumbnail window, and you can use various operations in these windows such as a slideshow.

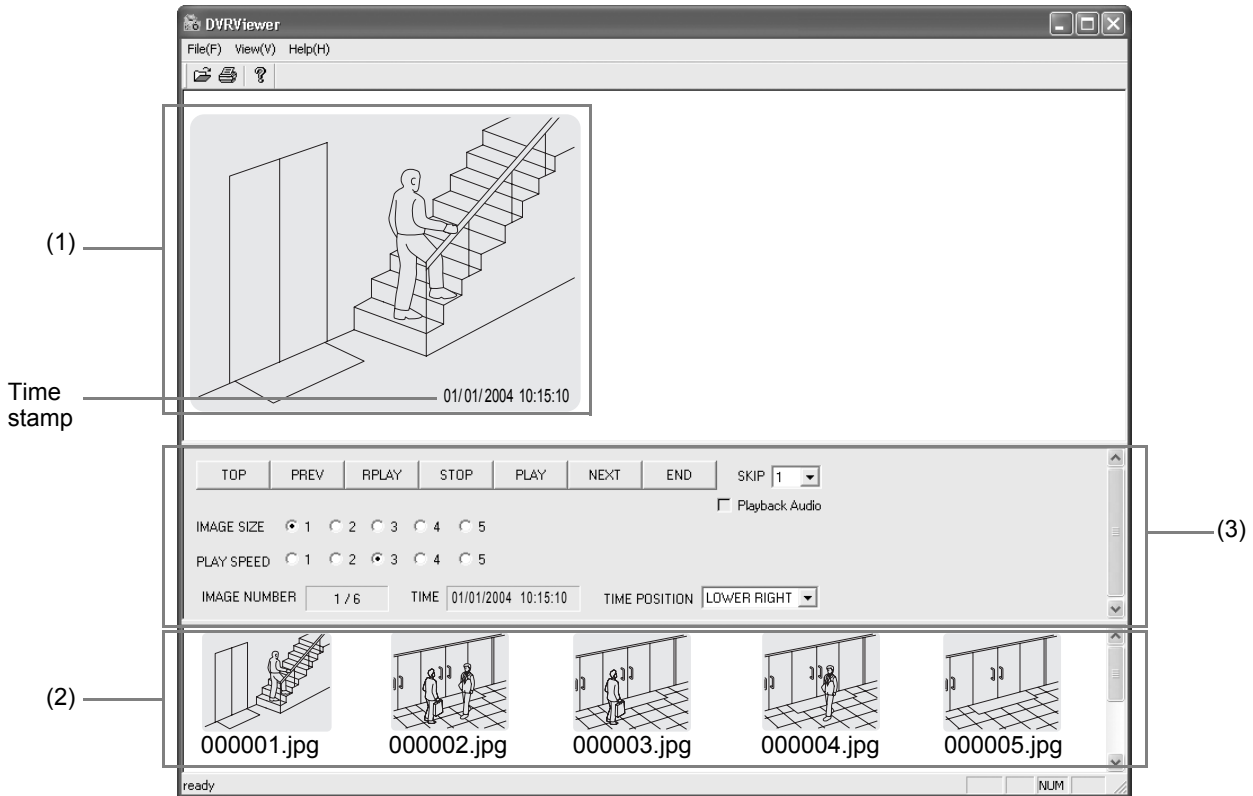

(1) Main window

When you double-click a thumbnail image, the image appears larger in the main window. When files are opened, the image whose file name has the smallest number will be displayed.

(2) Thumbnail window

All images that are stored in the specified folder appear as thumbnail images (compressed images) in ascending order of filename number. Thumbnail images that will not fit in the window can be viewed using the scroll bar.

(3) Control panel (→P. 44)

(3) Control panel

This is used for playback operations in the main window and to adjust the images.

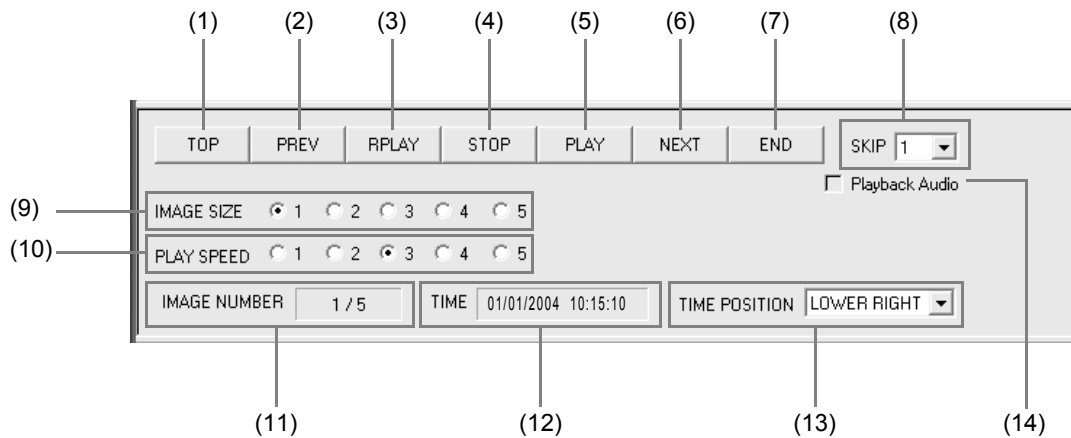

(1) [TOP]

Moves to the start of a slideshow.

(2) [PREV]

Moves to the previous image in a slideshow regardless of the setting for "(8) SKIP".

(3) [RPLAY]

Reverses back of the slideshow by skipping through the number of images specified by "(8) SKIP".

(4) [STOP]

Stops the slideshow.

(5) [PLAY]

Starts continuous playback of the slideshow by skipping through the number of images specified by "(8) SKIP".

(6) [NEXT]

Moves to the next image in a slideshow regardless of the setting for "(8) SKIP".

(7) [END]

Moves to the end of a slideshow.

(8) SKIP (Default setting: 1)

This sets the number of images that are skipped when playing and reverse playing slideshows. When using the default setting (= 1), all images are played back one at a time.

Setting values: 1, 2, 3, 4, 5, 10, 20, 30, 40, 50, 100, 200

(9) IMAGE SIZE (Default setting: 1)

The display size for images in the main window can be set to one of five sizes.

To display large image, select higher values.

1	400 × 300	4	1,024 × 768
2	640 × 480	5	1,280 × 960
3	800 × 600		

(10) PLAY SPEED (Default setting: 3)

The playback speed for slideshows can be set to one of five speeds.

1	1 sec	4	0.125 sec
2	0.5 sec	5	0.05 sec
3	0.25 sec		

! CAUTION

- The actual playback speed may vary depending on the computer's performance.

(11) IMAGE NUMBER

Shows "Current image number/Total number of images".

(12) TIME

Shows the time stamp for the displayed image.

! CAUTION

- The day, month and year order is defined by the settings at the computer.

(13) TIME POSITION (Default setting: LOWER RIGHT)

This specifies the display position for the time stamp.

Available settings: LOWER RIGHT, UPPER RIGHT, UPPER LEFT, LOWER LEFT

(14) Playback Audio

If this box is checked for a video file with audio, audio playback will be possible.

Printing images

Specified images can be printed as full screens together with date and time information.

1 To print the image in the main window

Select [Print (P)] from the [File (F)] menu, or click the  icon on the toolbar. The Windows print dialog box appears. Make any settings that are required such as selecting the printer and the number of copies to be printed, and then click [OK]. The main window will then be printed with the time stamp embedded in the image.

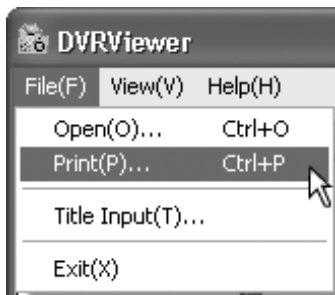

2 To print thumbnail images

Click the thumbnail image to be printed so that it appears in blue, and then repeat procedure 1 above.

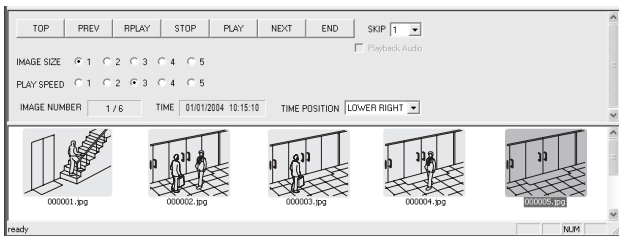

3 To print several images all at once

Hold down the [Ctrl] key on the keyboard, and then click on the images to be printed in the thumbnail window to select them. To select a contiguous range of images on the same line, hold down the [Ctrl] key and the [Shift] key simultaneously and then select the images. After selecting the images to be printed, carry out procedure 1 above. The selected images will then be printed one by one.

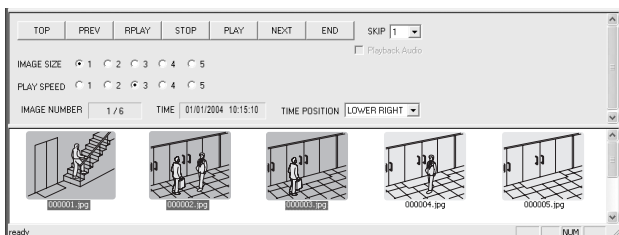

4 To display titles

To display titles for the images being printed, select [Title Input (T)] from the [File (F)] menu to display the Title Input dialog box.

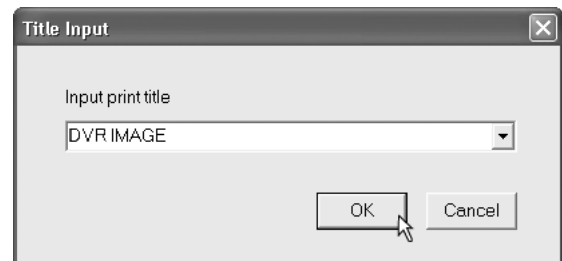
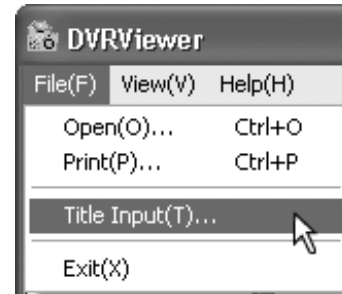

NOTE

- The title entered will appear underneath the printed image. Up to 10 entered titles can be saved and selected from a list.

